



OPERATING MANUAL



Zocon tipping trailer

Translated Operating Manual in English, original in Dutch

Zonderland Constructie B.V.

De Koevorde 6, 8502 TZ Joure, the Netherlands

T +31 (0)513 714334

F +31 (0)513 714332

E info@zocon.eu

I www.zocon.eu

Type: **Z030 / Z045 / Z050 / Z080 / Z100**

Date: 01-02-2020

Version: v1

FOREWORD

Congratulations on the purchase of a Zonderland product. You are now the owner of a quality product that will give you many years of excellent service.

Please ensure that you read this Operating Manual carefully to familiarise yourself with the correct control and maintenance procedures so that you can avoid personal injury or material damage. This Operating Manual belongs with the tipping trailer and should be passed on to the new owner in the event of resale or trade-in.

Please register the product identification numbers. Your Zonderland dealer will need these numbers when you order spare parts (please refer to the serial plate shown in paragraph 1.8).

Wherever the term 'manufacturer' is used in this document this refers to:

Zonderland Constructie BV in Joure.

Purpose of the Operating Manual

The purpose of the Operating Manual is to instruct the user of the tipping trailer as to its safe and correct operation. To this effect, the Operating Manual contains instructions about:

- personal and product safety issues that must be considered to avoid the risk of physical and/or material damage;
- optimal use of the tipping trailer;
- maintenance;
- storage of the tipping trailer;
- disposal of the tipping trailer.

Target group

This Operating Manual is for users of the tipping trailer and for associated dealers and importers.

User of the tipping trailer

The tipping trailer may only be used by a person who:

- has reached the legally permitted minimum age for driving a tractor;
- has read and thoroughly understood the instructions provided in this Operating Manual.







OBSERVATION:

The **standard** version of the tipping trailer is not permitted on public roads in EU countries. Please refer to paragraph 2.3.7 for modifications.

Reference guide

The following symbols and terms are used in this Operating Manual to make the reader aware of safety aspects and essential information:

SYMBOL	TERM	MEANING
	DANGER	Indicates a dangerous situation that could lead to serious or fatal injuries if the safety instructions are not followed.
	WARNING	Indicates a dangerous situation that may lead to serious or fatal injury and/or substantial damage to the product or environment if the safety instructions are not followed.
	ATTENTION	Indicates a dangerous situation that may lead to minor and/or moderate damage to the product or environment if the safety instructions are not followed.
	OBSERVATION	Provides essential information.

Abbreviations used

Abbreviation	Meaning
Zocon	Zonderland Constructie B.V.
CE	Conformité Européenne (Marking - Complies with European legislation)
PPE	Personal Protective Equipment

CONTENTS

FOREWORD	2
PURPOSE OF THE OPERATING MANUAL	2
TARGET GROUP	2
USER OF THE TIPPING TRAILER	2
REFERENCE GUIDE.....	3
ABBREVIATIONS USED.....	3
CONTENTS	4
1. INTRODUCTION	7
1.1 INTENDED USE	7
1.2 NON-INTENDED USE.....	8
1.3 LIFETIME	8
1.4 MODIFICATIONS.....	8
1.5 CE DECLARATION.....	9
1.6 OPERATING ENVIRONMENT	10
1.7 WARRANTY.....	10
1.8 EXPLANATION OF SERIAL PLATE.....	11
1.8.1 <i>Vehicle category</i>	11
1.8.2 <i>Type of tipping trailer</i>	12
2. DESCRIPTION	13
2.1 CONSTRUCTION	13
2.2 TECHNICAL SPECIFICATIONS.....	15
2.3 AVAILABLE OPTIONS	18
2.3.1 <i>Three-sided tipping</i>	18
2.3.2 <i>Extensions</i>	19
2.3.3 <i>Shreds cover</i>	19
2.3.4 <i>Folding doors</i>	20
2.3.5 <i>Tyres</i>	20
2.3.6 <i>Drawbar couplings</i>	21
2.3.7 <i>Adjustments for driving on public roads</i>	21
2.3.8 <i>Braking systems</i>	23
3. SAFETY	32
3.1 GENERAL SAFETY INSTRUCTIONS	32
3.2 WARNING SYMBOLS	33
3.2.1 <i>Safety stickers</i>	34
4. CHECKS BEFORE DRIVING OFF	35
4.1 DIMENSIONS	35

5.	OPERATION	36
5.1	REAR TAILGATE.....	36
5.1.1	<i>Rear tailgate locking hooks</i>	36
5.1.2	<i>Hydraulic rear gate locking.....</i>	38
5.1.3	<i>Folding doors.....</i>	38
5.1.4	<i>Operation of locking hooks on use of folding of doors.....</i>	39
5.2	SIDE BOARDS.....	39
5.2.1	<i>Manual locking of the side boards.....</i>	40
5.2.2	<i>Hydraulic side board locking</i>	41
5.3	BRAKING SYSTEM	42
5.3.1	<i>Overrun brake.....</i>	43
5.3.2	<i>Hydraulic braking system (1-circuit)</i>	45
5.3.3	<i>Hydraulic braking system (2-circuit)</i>	46
5.3.4	<i>Manual pneumatic braking system (2-circuit)</i>	48
5.3.5	<i>Automatic pneumatic braking system (2-circuit).....</i>	51
5.4	TIPPING THE BODY.....	52
5.4.1	<i>Selecting the direction of tipping.....</i>	52
5.4.2	<i>Hydraulic tipping.....</i>	53
5.4.3	<i>Mechanical safety bar</i>	54
6.	COMMISSIONING	55
6.1	SPECIFIC RISKS AND DANGERS	55
7.	OPERATION	57
7.1	PREPARATORY TASKS.....	57
7.2	ADJUSTMENT OF THE TIPPING TRAILER.....	57
7.2.1	<i>Adjustment of the drawbar</i>	57
7.3	COUPLING TO THE TRACTOR	58
7.3.1	<i>For spindle-type parking jack:.....</i>	59
7.3.2	<i>For hydraulic parking jack:.....</i>	60
7.3.3	<i>For overrun brake:.....</i>	61
7.3.4	<i>For hydraulic brake (1-circuit system):.....</i>	62
7.3.5	<i>For hydraulic brake (2-circuit system):.....</i>	64
7.3.6	<i>For hydraulic 2-circuit braking system and 1-circuit tractor:.....</i>	67
7.3.7	<i>For pneumatic brake.....</i>	68
7.4	UNCOUPLING FROM THE TRACTOR.....	69
7.4.1	<i>For spindle-type parking jack:.....</i>	69
7.4.2	<i>For hydraulic parking jack:.....</i>	69
7.4.3	<i>Uncoupling:.....</i>	69
7.5	CHOICE OF TIPPING DIRECTION.....	70
7.5.1	<i>Standard rearward tipping:.....</i>	70
7.5.2	<i>Sideways tipping:.....</i>	73
7.5.3	<i>Position of hydraulic valves during tipping operations.....</i>	74
7.6	DURING OPERATIONS	75
7.6.1	<i>Loading the body.....</i>	75
7.6.2	<i>Tipping the body.....</i>	75
7.7	HOISTING OF HEAVY COMPONENTS	76
7.7.1	<i>Hoisting procedure for side boards.....</i>	77
7.7.2	<i>Fitting the extensions and gauze cover.....</i>	77

8. MAINTENANCE	78
8.1 GENERAL MAINTENANCE.....	78
8.2 INSPECTIONS	79
8.2.1 Handbrake.....	79
8.2.2 Functioning of the braking device / break-out safety.....	79
8.2.3 Adjustment of rear tailgate locking hooks	79
8.2.4 Wheel replacement.....	80
8.3 PERIODIC MAINTENANCE.....	82
8.3.1 Lubrication points.....	82
8.3.2 Lubricants to be applied.....	82
8.3.3 Daily maintenance	84
8.3.4 Annual maintenance.....	84
9. FAILURES	85
9.1 BREAK-OUT BRAKING DEVICE	85
9.2 LIGHTING	86
9.3 ELECTRIC PLUG CONNECTIONS.....	87
9.3.1 ABS plug for hydraulics	87
9.3.2 Trailer plug for lighting	88
10. TAKING THE TIPPING TRAILER OUT OF OPERATION	89
10.1 STORAGE OF THE TIPPING TRAILER.....	89
10.1.1 Preparatory work for short-term storage.....	89
10.1.2 Preparatory work for long-term storage	89
11. DISASSEMBLY AND DISPOSAL	90
11.1 DISASSEMBLY.....	90
11.2 DISPOSAL	90
12. OVERVIEW OF FIGURES AND TABLES	91
12.1 FIGURES:.....	91
12.2 TABLES:.....	92
13. APPENDIXES	93

1. INTRODUCTION

This Operating Manual is intended for those who will be operating the machine and performing daily maintenance.

Users must read the entire Operating Manual before commencing operation of any kind.

This Operating Manual covers the correct manner of operation, safety precautions, maintenance and transport.

The Operating Manual also describes components that are available as an option.

Any discrepancies between the wording and/or illustrations in the Operating Manual and your machine may result from different machine versions or such changes as may result from ongoing development and innovation.

1.1 Intended Use

The tipping trailers are intended solely for the transport and autonomous discharging of agricultural crops such as potatoes, sugar beet and other root crops, cereals, hay etc. as well as for other materials such as sand, fertilisers/manure, wood chips, gravel etc.



ATTENTION

Always ensure that the maximum permitted loading capacity is not exceeded!

Please refer to *Table 2-1*

The tipping trailer has been built in accordance with the requirements of the European Directive 167/2013, which implies that the trailer meets the European requirements for the carrying of a license plate and is eligible for the obtaining of a vehicle registration card. The use of the tipping trailer on public roads is permitted (albeit not in all countries in the standard configuration).

The maximum permitted speed on public roads without a license plate is 30 km/h (40 km/h if fitted with an overrun brake). Be sure to observe the technical maximum speed if this is lower than the permitted statutory speed limit.

1.2 Non-Intended use



ATTENTION

Use of the tipping trailer for purposes for which it is not intended may endanger the safety of persons and cause material damage to the tipping trailer.



OBSERVATION:

Non-intended use of the tipping trailer will invalidate the product warranty.

The tipping trailer must not:

- be operated by persons below the locally permitted age;
- be used on public roads in the EU unless the trailer has been fitted with the required options (please refer to paragraph 2.3.7);
- be charged with loads in excess of the maximum load as specified on the serial plate (please refer to paragraph 1.8);
- be used for the transportation of persons;
- be used with a passenger car fitted with a tow bar.

1.3 Lifetime



ATTENTION:

To ensure the correct and safe operation of the tipping trailer throughout its lifetime it must be checked annually by an authorised inspection service.

Based upon correct use and maintenance, the tipping trailer has:

- an economic lifetime of 10 years;
- a technical lifetime of 20 years.

1.4 Modifications

Modification of the tipping trailer is not permitted without consultation with the manufacturer to obtain their approval. Any contravention of this condition may invalidate the warranty, please refer to paragraph 1.7.

1.5 CE Declaration



Zonderland Constructie B.V.

De Koevorde 6
8502 TZ JOURE
The Netherlands
Tel.: +31 (0)513 714334
Fax.:+31 (0)513 714332
E-mail: info@zocon.eu
Web: <http://www.zocon.eu>

Zonderland Constructie BV declares that the machine

Zocon Tipping Trailer	
Standard function:	Tipping trailer for agricultural transport
Type:	Z030 / Z045 / Z050 / Z080 / Z100
Serial number:	From XL9000000J0611050

complies with Directive **2006/42/EC** of the European Parliament and Council for machines, dated 17 May 2006, as well as with the amendment of Directive 95/16/EC (Official EU volume L 157/24 of 9 June 2006).

The person responsible for the composition of the technical details is the head of the Research & Development department of Zonderland Constructie BV.

This declaration pertains only to machines in the specification in which they are offered for sale by the manufacturer, and excludes any components and/or modifications that may have been added afterwards.

Place: Joure

Date: 16 February 2018



Jochem Zonderland
Owner of Zonderland Constructie B.V.
Zonderland Constructie B.V.
De Koevorde 6
8502 TZ JOURE
The Netherlands

1.6 Operating environment

The tipping trailer has been designed for use on agricultural land and on public roads (please note: use of the standard version on public roads may not be permitted).

Appropriate tyres can be selected depending on the type of surface soil. Please refer to *Table 8-1*.

1.7 Warranty

The manufacturer guarantees that the tipping trailer meets the usually applicable requirements and standards, and that it is free from any defect. This warranty applies for a period of twelve months from delivery, and covers only the replacement of defective parts.

This warranty shall not apply if the failure has been caused by injudicious or non-intended use.



OBSERVATION:

Non-intended use of the tipping trailer will invalidate the product warranty.

Any repairs carried out within the warranty period are subject to the manufacturer's approval.



OBSERVATION:

If repairs are carried out without prior consultation with and permission from the manufacturer the costs will be completely for the user's account and compensation cannot be claimed from the manufacturer.

The tipping trailer has been built in accordance with the requirements of the European Directive 167/2013, which implies that the trailer meets the European requirements for obtaining a vehicle registration.

Any modifications performed by the user themselves may affect the category of the vehicle approval, and the vehicle must then be presented anew to the national inspection service to obtain permission for use on public roads.

1.8 Explanation of serial plate

The serial plate is situated on the R/H side of the chassis, underneath the body:

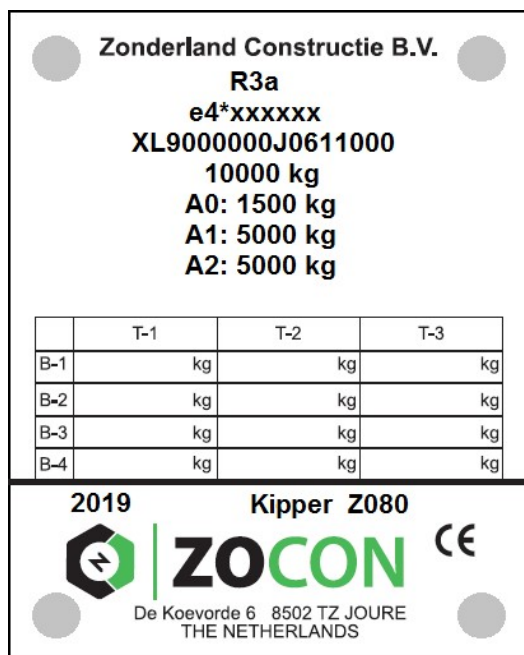

Explanation of serial plate:

- Name of manufacturer
- Vehicle category
- EU Approval Number
- VIN Number
- Permissible maximum total weight
- Permissible maximum total weight on the drawbar
- Permissible maximum total weight on the 1st axle
- Permissible maximum total weight on the 2nd axle

Table specifying permissible maximum weights for a 2nd trailed trailer, if any

- Build year and type of tipping trailer
- Zocon brand name and CE logo
- Address of manufacturer

Figure 1-1: Model of serial plate

1.8.1 Vehicle category



OBSERVATION:

In its **standard configuration** the tipping trailer does not fall under EU Directive 167/2013 and may therefore not be used on public roads without the required options.

All vehicles to be used on public roads in the EU are divided into categories (refer to EUR-Lex - 32013R0167 – EN).

For agricultural use, the tipping trailer falls in category **R3a**.

All the tipping trailers referred to in this Operating Manual fall in the category R3a, which means:

- a trailed trailer for agricultural purposes (category R);
- with a total axle load in excess of 3,500 kg up to 21,000 kg (category 3);
- with a maximum speed of up to 40 km/h (category a).

Obviously, technical restrictions account for the permissible maximum axle load and speed of each tipping trailer. Please refer to *Table 2-1*.

1.8.2 Type of tipping trailer

The type number of the tipping trailer starts with 'Z', followed by a number. This number, multiplied by 100, represents the approximate loading capacity of the tipping trailer.

For example: Type: Z050, loading capacity = 5,000 kg (50 x 100).

The range includes 5 types:

- Z030 = 3,000 kg loading capacity*
- Z045 = 4,500 kg loading capacity*
- Z050 = 5,000 kg loading capacity*
- Z080 = 8,000 kg loading capacity*
- Z100 = 10,000 kg loading capacity*

** The actual loading capacity may vary depending on technical limits.*

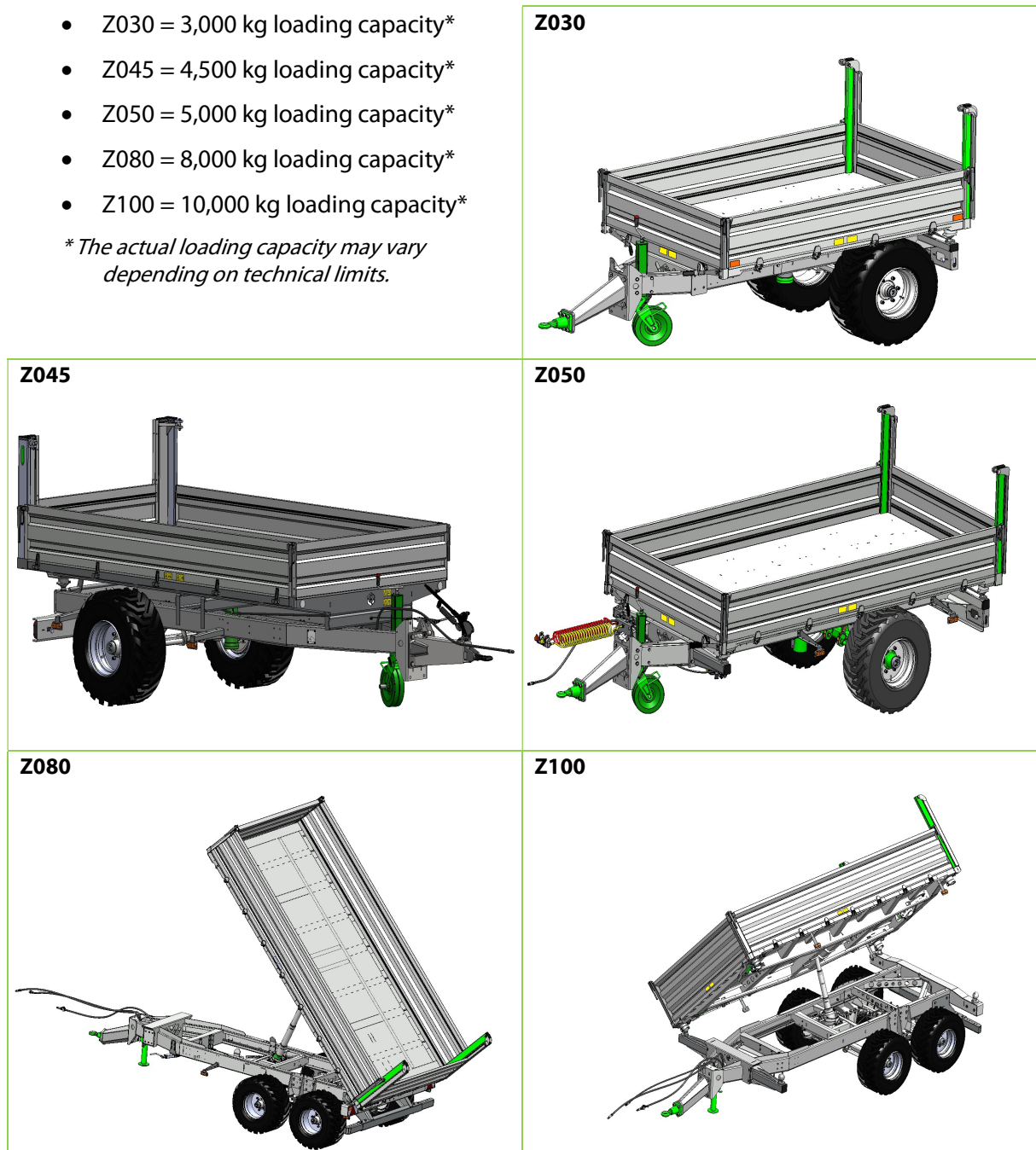

Figure 1-2: Various types of tipping trailer

2. DESCRIPTION

2.1 Construction

The tipping trailer consists of a chassis on wheels [1] onto which a tiltable body [3] is fitted. According to the type of tipping trailer and the options selected, the body can be tipped sideways as well as to the rear.

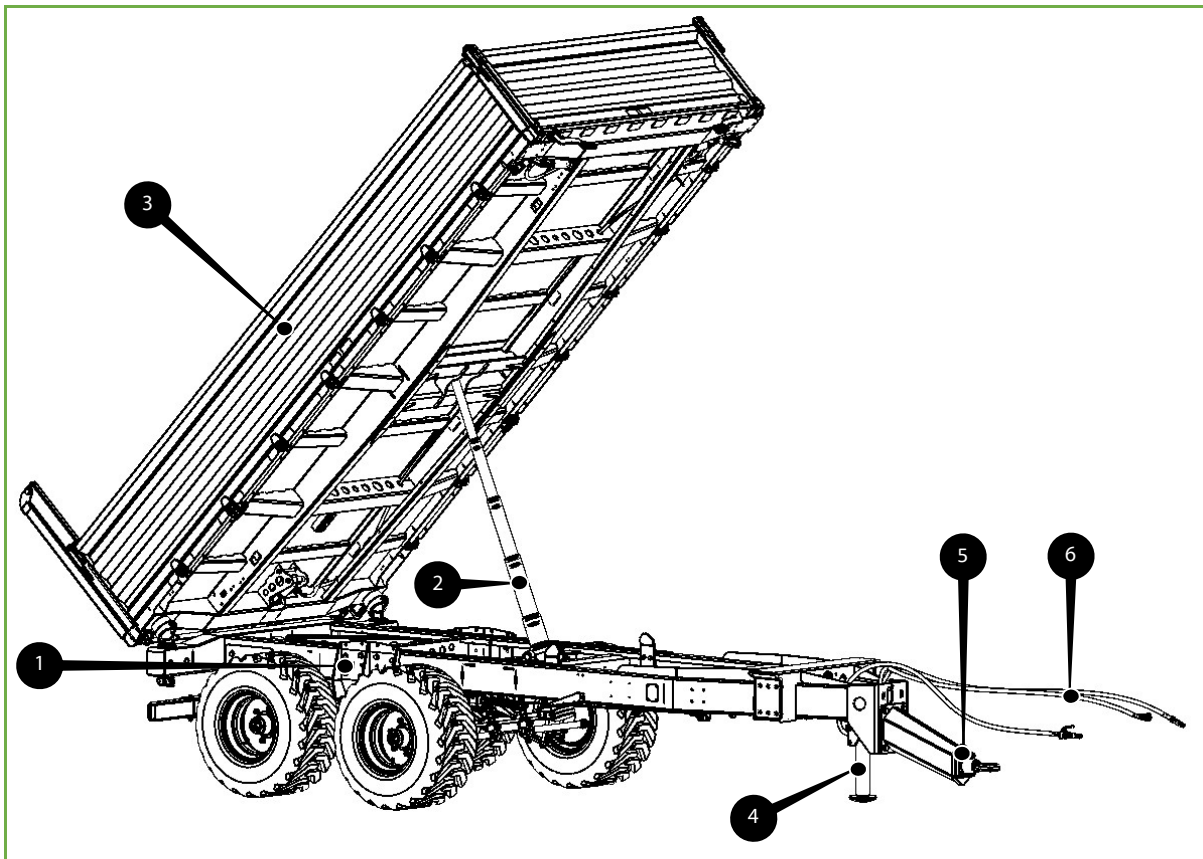

Figure 2-1: Coupling of tipping trailer to tractor

- 1 - Chassis on wheeled carriage
- 2 - Hydraulic tilt ram
- 3 - Body
- 4 - Parking jack
- 5 - Drawbar with drawbar eye
- 6 - Tractor connections

The construction is made of galvanised steel to ensure optimal corrosion resistance and maximum durability.

The complete assembly is carried on a single axle or, in the case of the two largest models, a tandem axle.

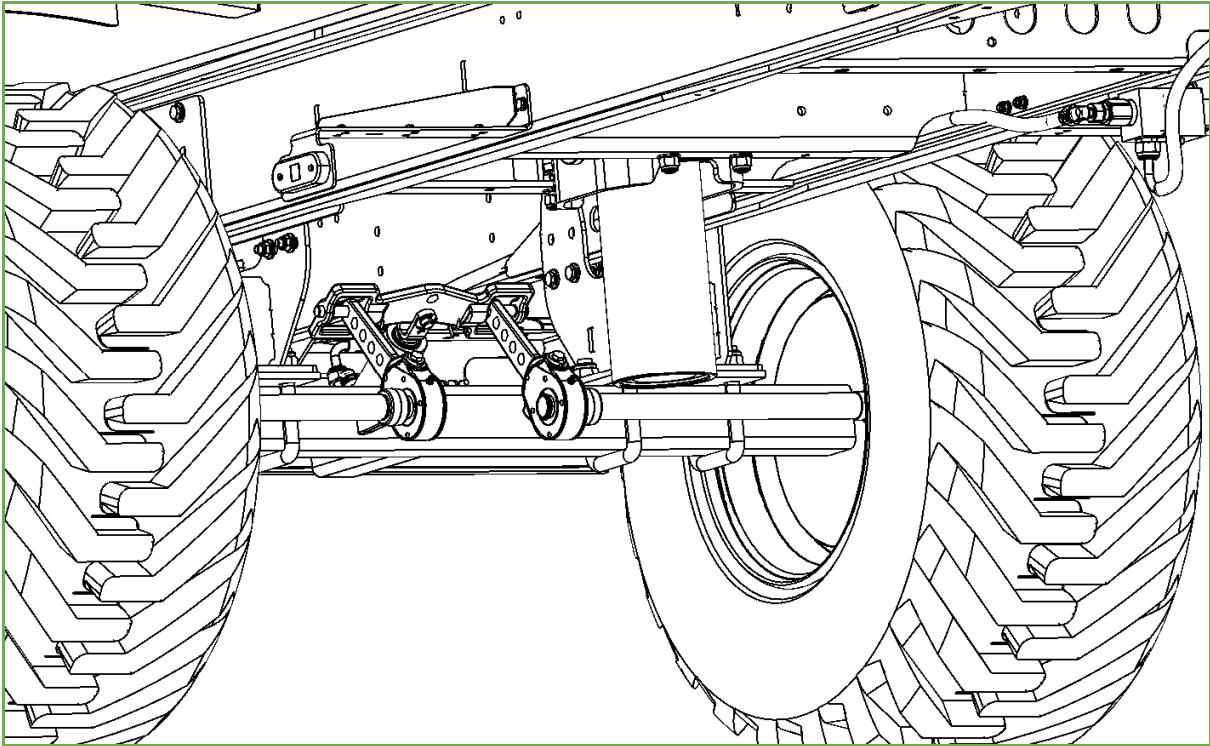

Figure 2-2: Non-spring-loaded single-axle trailer (with hydraulic brakes)

The tipping trailer is fitted with a height-adjustable drawbar. This drawbar is adjusted to the height of the linkage point on the tractor. The drawbar is bolted onto the chassis and can be fitted in several positions. Please refer to paragraph 7.2.1. There are two types of drawbar: a fixed drawbar and a version including an overrun brake.

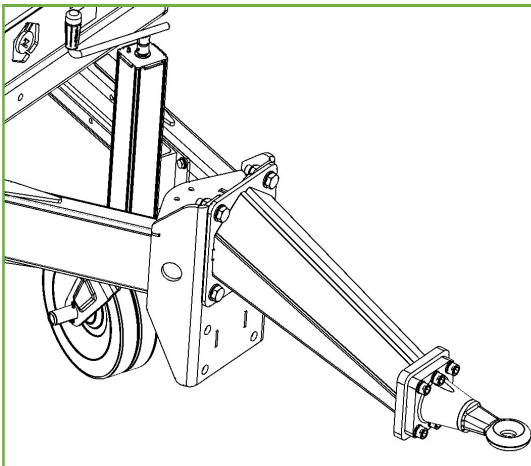

Figure 2-3: Fixed drawbar (pivotable drawbar eye)

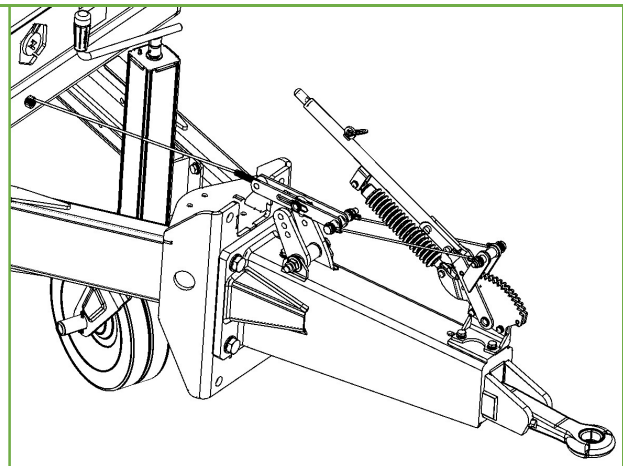

Figure 2-4: Drawbar with overrun brake (non-pivotable drawbar eye)

To facilitate the parking of the tipping trailer as a free-standing vehicle, it is fitted with either a spindle-type parking jack or a hydraulic parking jack.

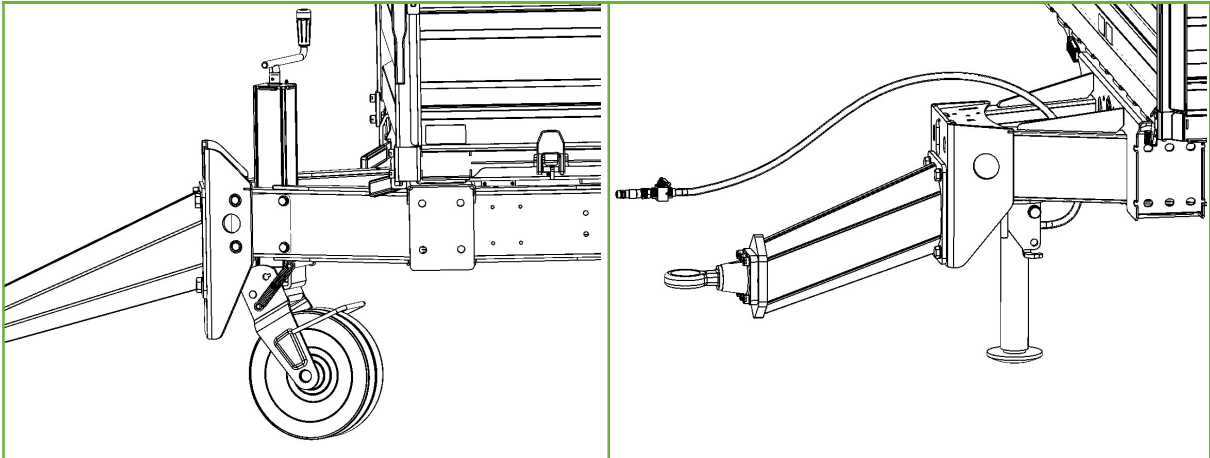

Figure 2-5: Spindle-type parking jack

Figure 2-6: Hydraulic parking jack

2.2 Technical specifications

Please refer to *Table 2-1* for an overview of specifications per type of tipping trailer.



OBSERVATION:

The available options are listed in *Table 2-1* marked with *.

Dimensions apply to the standard version.

Please refer to *Table 8-1* for an overview of tyre options per type of tipping trailer.

Table 2-1: Overview of models Z030, Z045 and Z050 with available options

Type:	Z030	Z045	Z050
Max. loading capacity (kg)	3,000	4,500	5,000
Unladen weight (kg)	750	1,200	1,400
Max. total weight (kg)	4,550	5,800	6,000
Body dimensions (cm)	240 x 150 x 40	340 x 180 x 40	340 x 180 x 40
Transport width (m)	1.70	1.95	1.95
Transport height (m)	1.80	1.90	1.90
Transport length (m)	3.70	4.85	4.75
Number of tipping sides	Rear (or 3-sided*)	Rear end only	Rear (or 3-sided*)
Tailgate locking	Automatic	Automatic	Automatic
Side walls (h, mm)	Removable Fold up and down 400	Removable Fold down only 400	Removable Fold up and down 400
Side wall locking	Manual	Manual/not for rearwards tipping only	Manual
Body extension (closed – height in mm)	400 + 400*	400 + 400*	400 + 400*
Gauze extension (height in mm)	Gauze extension 800*	Gauze extension 800*	Gauze extension 800*
Axle	Single	Single	Single
Standard brake system	Non-braked	Non-braked	Non-braked
Brake option*	Overrun brake*	Overrun brake*	Overrun brake*
Hydraulic brake system 1 circuit system*	1 circuit system*	1 circuit system*	1 circuit system*
Hydraulic brake system 2 circuit system*	2 circuit system*	2 circuit system*	2 circuit system*
Pneumatic brake system*	Pneumatic (2 circuit system)*	Pneumatic (2 circuit system)*	Pneumatic (2 circuit system)*
Rear tailgate as standard/ folding doors*	Rear tailgate/ folding doors*	Rear tailgate/ folding doors*	Rear tailgate/ folding doors*
Parking jack	Manual control / Hydraulic*	Manual control / Hydraulic*	Manual control / Hydraulic*
Lighting	Halogen/ LED*	Halogen/ LED*	Halogen/ LED*
Noise emission	< 70 dB (A)	< 70 dB (A)	< 70 dB (A)

Table 2-2: Overview of models Z080 – Z100 with available options

Type:	Z080 tandem axle	Z080 single axle*	Z100 tandem axle	Z100 single axle*
Max. loading capacity (kg)	8,000	8,000	10,000	10,000
Unladen weight (kg)	2,300	2,100	2,700	2,500
Max. total weight (kg)	10,500		12,000	
Body dimensions (cm)	450 x 220 x 60	450 x 220 x 60	450 x 220 x 60	450 x 220 x 60
Transport width (m)	2.28	2.28	2.28	2.28
Transport height (m)	2.25	2.25	2.26	2.26
Transport length (m)	5.80	5.80	5.90	5.90
Number of tipping sides	Rear (or 3-sided*)	Rear (or 3-sided*)	Rear (or 3-sided*)	Rear (or 3-sided*)
Tailgate locking	Hydraulic	Hydraulic	Hydraulic	Hydraulic
Side walls (height in mm)	Removable Fold up and down 600	Removable Fold up and down 600	Removable Fold up and down 600	Removable Fold up and down 600
Side wall locking	Manual / hydraulic*	Manual / hydraulic*	Manual / hydraulic*	Manual / hydraulic*
Body extension (closed – height in mm)	400 + 400*	400 + 400*	400 + 400*	400 + 400*
Gauze extension (height in mm)	Gauze extension 800*	Gauze extension 800*	Gauze extension 800*	Gauze extension 800*
Axle	Tandem	Single*	Tandem	Single*
Standard brake system	Hydraulic (1 circuit system)	Hydraulic (1 circuit system)	Hydraulic (1 circuit system)	Hydraulic (1 circuit system)
Hydraulic brake system 2 circuit system*	2 circuit system*	2 circuit system*	2 circuit system*	2 circuit system*
Pneumatic brake system*	Pneumatic (2 circuit system)*	Pneumatic (2 circuit system)*	Pneumatic (2 circuit system)*	Pneumatic (2 circuit system)*
Rear tailgate as standard/ folding doors*	Rear tailgate/ folding doors*	Rear tailgate/ folding doors*	Rear tailgate/ folding doors*	Rear tailgate/ folding doors*
Parking jack	Hydraulic parking jack	Hydraulic parking jack	Hydraulic parking jack	Hydraulic parking jack
Lighting	Halogen/ LED*	Halogen/ LED*	Halogen/ LED*	Halogen/ LED*
Noise emission	< 70 dB (A)	< 70 dB (A)	< 70 dB (A)	< 70 dB (A)

Options are marked with *

Dimensions apply to the standard version

2.3 Available options

2.3.1 Three-sided tipping

In addition to the standard rearwards tipping feature, all models with the exception of type Z045 can be equipped for three-sided tipping. In that case, the front of the chassis is fitted with additional supports [5] on which the body can tilt sideways.

Locks with rods [3] are mounted to the side boards to facilitate easy opening and locking. Types Z080 and Z100 are equipped with a hydraulic side-unlocking system. Please refer to *Figure 5-8*.

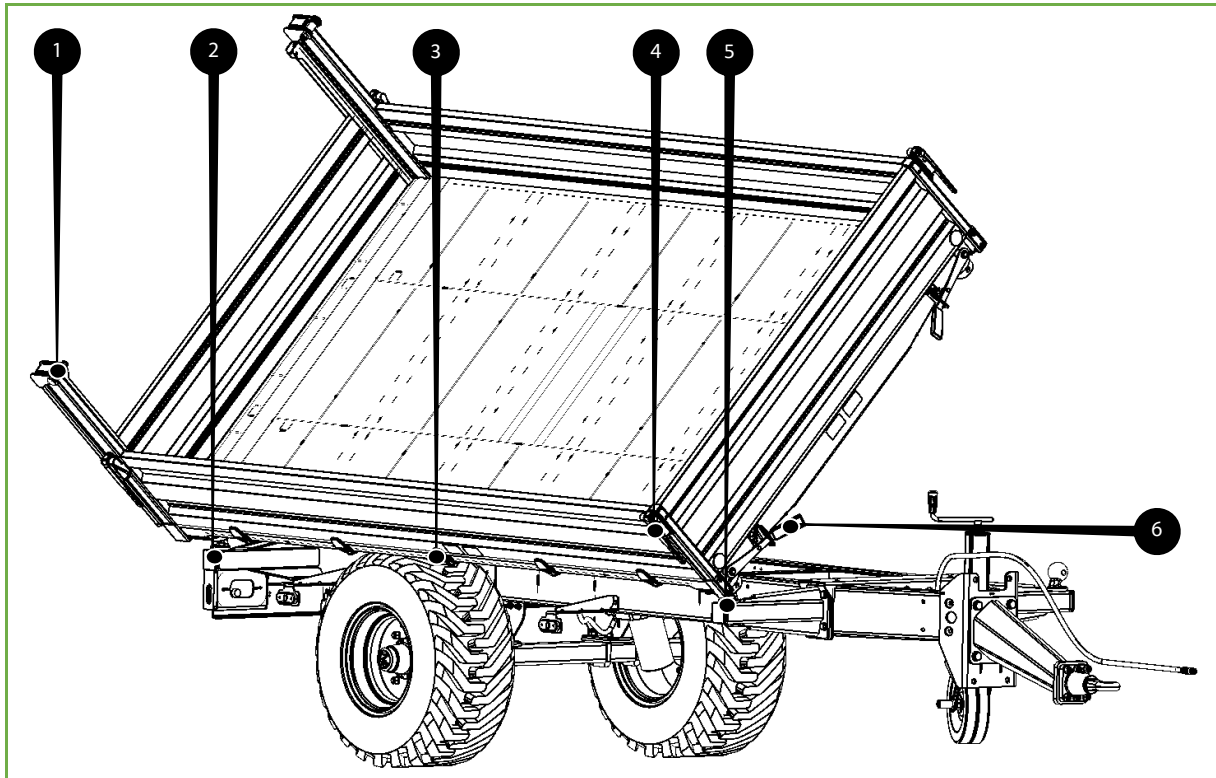

Figure 2-7: Sideways tipping

- 1 - Rear tailgate top hinge (2 x)
- 2 - Pivot point on chassis for rearwards and sideways tipping
- 3 - Side board lower hinge (for downwards tipping of the board)
- 4 - Side board top hinge and lock (for downwards tipping of the board)
- 5 - Pivot point support for sideways tipping
- 6 - Securing arm for side board locking (optional hydraulic control)

2.3.2 Extensions

Additional extensions [2] can be fitted to the top of the standard side and rear walls. These extensions have a height of 400 mm and a maximum of 2 extra extensions can be mounted. The purpose of the extensions is to enable the loading of high-volume, lighter loads up to the trailer's maximum charging capacity. A gauze extension with a height of 800 mm is also available as an additional extension option.

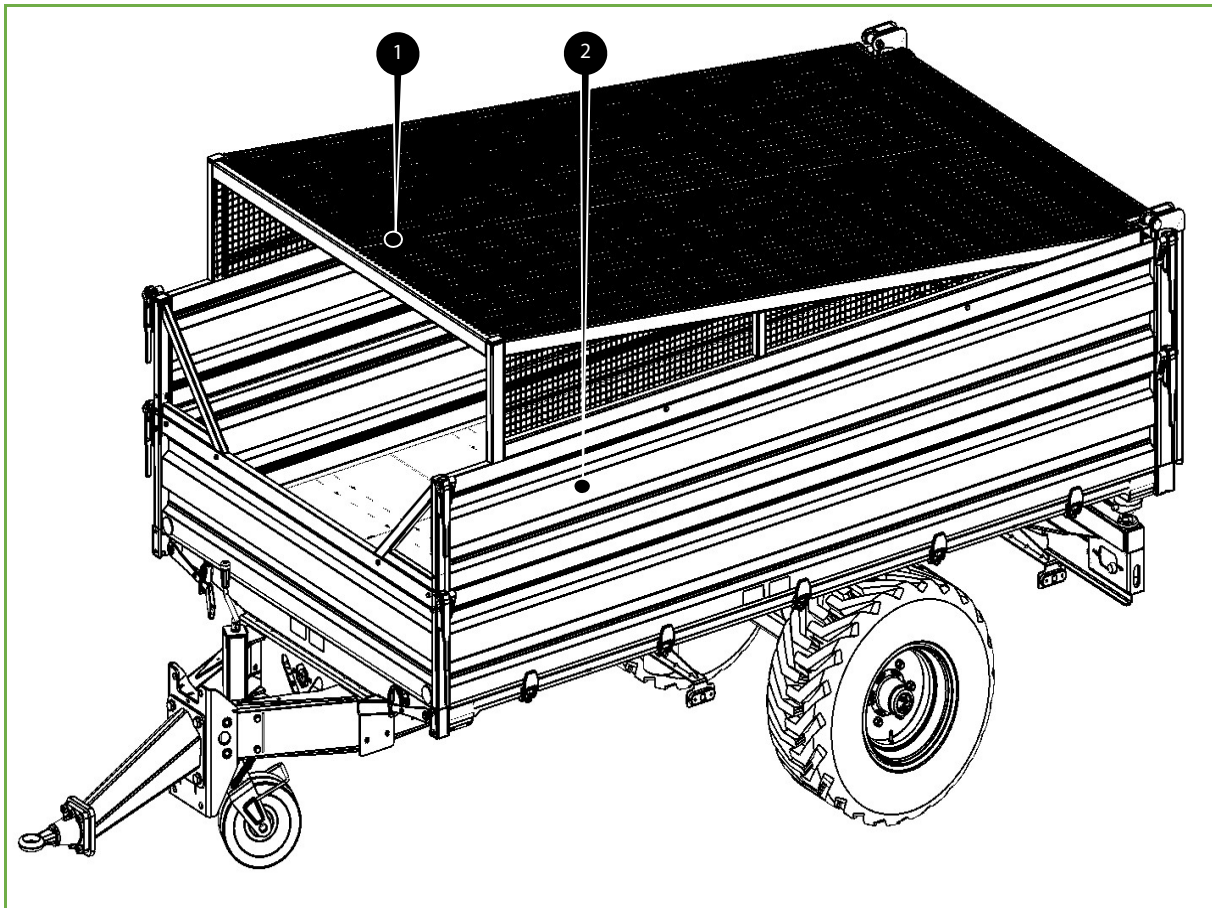

Figure 2-8: Shreds cover with open front wall and extension

- 1 - Shreds cover
- 2 - Extension



OBSERVATION:

The extensions on the sides do not pivot; the trailer can be discharged sideways using the lower side boards.

2.3.3 Shreds cover

A shreds cover [1] may be fitted if a machine with a propelled air outlet, such as a leaf blower or chopper, is being used. This option covers the top of the tipping trailer completely with gauze. There is an inlet opening at the front through which the material can be blown. Please refer to *Figure 2-8*.

2.3.4 Folding doors

A pivoting rear tailgate is fitted as standard but folding doors can be installed as an option. Please refer to *Figure 2-9*. These doors pivot fully outwards, allowing the load to pass through freely. The doors [3] are fitted with an upper and lower lock [1].

The doors are fitted within a frame so that the rear tailgate can also be opened as a whole by means of the upper hinges. The frame is locked [2] when the folding doors are in use.

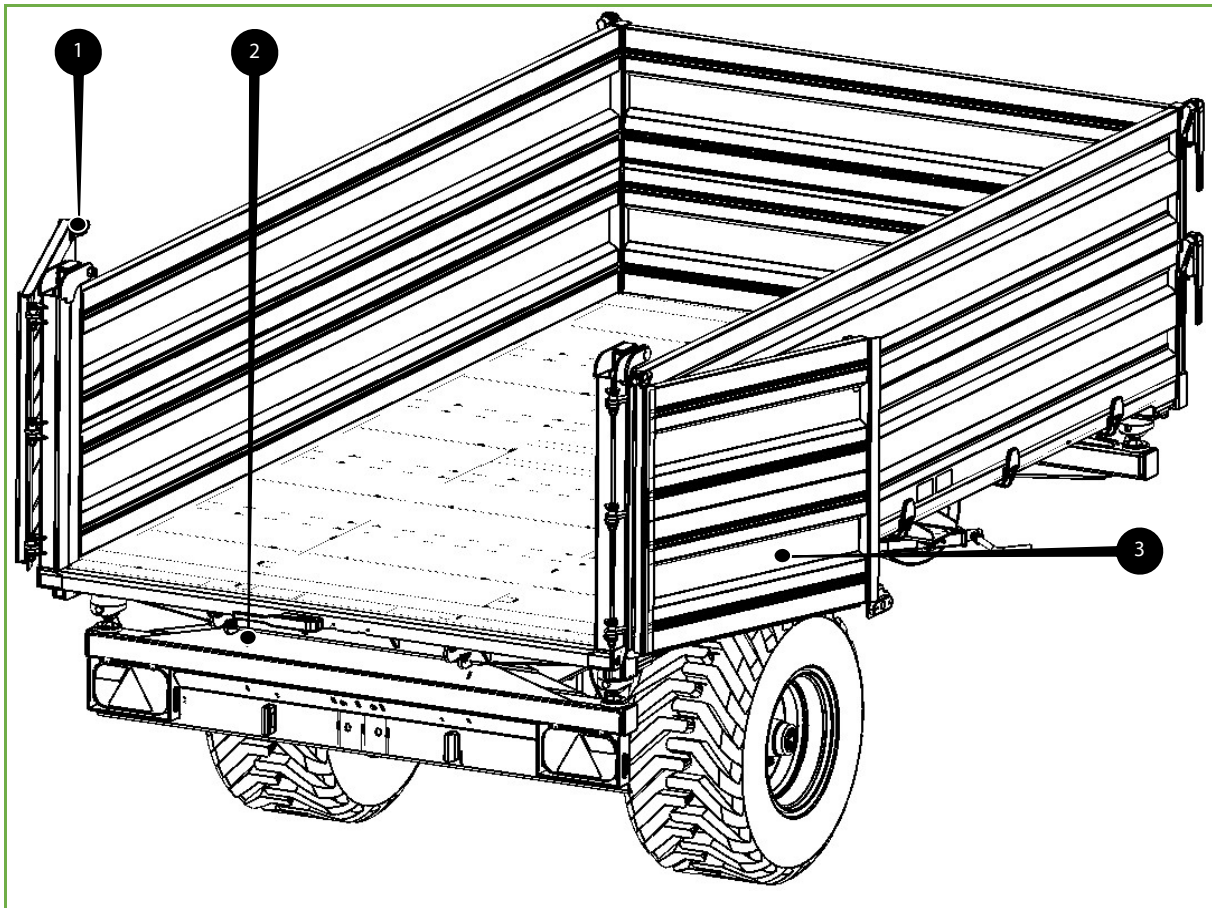

Figure 2-9: Folding doors (with extension)

- 1 - Door lock (2 x)
- 2 - Lower lock on rear tailgate frame
- 3 - Folding door (2 x)

2.3.5 Tyres

In addition to the standard tyres, various other types of tyre are available as an option.

Please refer to *Table 8-1* for an overview of all tyres.

2.3.6 Drawbar couplings

A choice can be made from the following couplings:

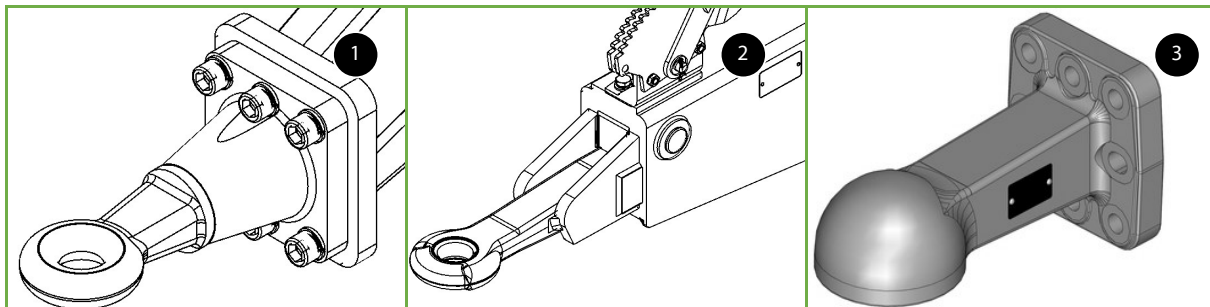

Figure 2-10: Various couplings

- 1 - Fixed or pivotable drawbar eye
- 2 - Non-pivotable drawbar eye in combination with an overrun brake
- 3 - Ball head coupling with \varnothing 80 mm ball



OBSERVATION:

In common with all vehicles on public roads in Europe, the tipping trailer must comply with the European Directive 94/20/EG2 in terms of the coupling.

Please refer to paragraph **Fout! Verwijzingsbron niet gevonden.** for the correct drawbar height adjustment.

2.3.7 Adjustments for driving on public roads

The tipping trailer can be fitted with the following options.

- An automatic braking system that will engage in the event of the breaking out of the tipping trailer (break-out braking system):
 - An overrun brake for vehicles with a total weight of up to 8,000 kg. The overrun brake is fitted with a break-out safety cord between the handbrake and the tractor. The cord operates as a safety device and pulls on the hand brake in the event of the breaking out of the tipping trailer.
 - A hydraulic 2-circuit break-out braking system.
 - A pneumatic 2-circuit break-out braking system.
- Lighting:
 - Tipping trailer rear side (two rear lights [1] with brake light, direction indicator and licence plate lighting). Please refer to Figure 2-11.
 - If the length is in excess of 4.6 m (shaft included): side signalling lights on both sides, at least 2 x per side on the front and rear, amber-coloured [1].
- Licence plate [3] including vehicle registration card.

- 1 - Rear light with direction indicator and brake light
- 2 - Licence plate lighting
- 3 - Licence plate
- 4 - Rear bumper

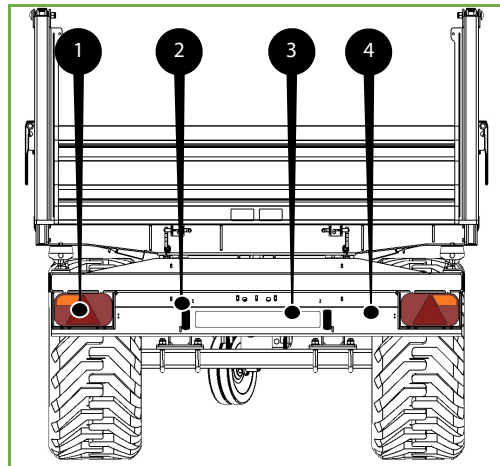

Figure 2-11: Lighting and licence plate

- Retroreflectors: a trailer with a length in excess of 4.6 m (drawbar included) must carry visibility aids on the side in the form of retroreflectors and side lighting.
 - Front: 2 reflectors; colour white.
 - Rear: 2 reflectors; colour red.
 - Sides: If the length is in excess of 4.6 m (shaft included): side reflectors on both sides, at least two reflectors at the front and rear of each side, colour amber.
- Securing shingles or ropes to secure the cargo so that it cannot fall from the tipping trailer or be blown out of it upon sudden braking, swerving, manoeuvring, or as a result of poor road surfaces.

In addition, the following rules apply to trailers.

- The weight of the cargo must not exceed the maximum weight specified on the vehicle registration card.
- The cargo must not protrude more than 20 cm on either side.
- Maximum width 2.55 m.
- The cargo may protrude up to a maximum of 1 metre at the rear.
 - If the cargo protrudes more than 1 m at the rear, a warning sign (with red and white diagonal stripes) must be used. If such a panel is mounted to the trailer, the cargo may protrude up to half the trailer's length as a maximum, up to a maximum of five metres.
 - A red light must be fitted to the end of the protruding cargo if the trailer is driven in the dark.
- The maximum permitted height, inclusive of cargo is 4 m.

2.3.8 Braking systems



OBSERVATION:

In common with all vehicles on public roads in Europe, the braking system of the tipping trailer must comply with European Directive 71/320/EEG1.

- **Non-braked**

The Z030, Z045 and Z050 models of the tipping trailer are not equipped with a braked axle **as standard**. These versions are therefore not allowed on public roads in some countries. Please refer to paragraph 5.3 for braked options.

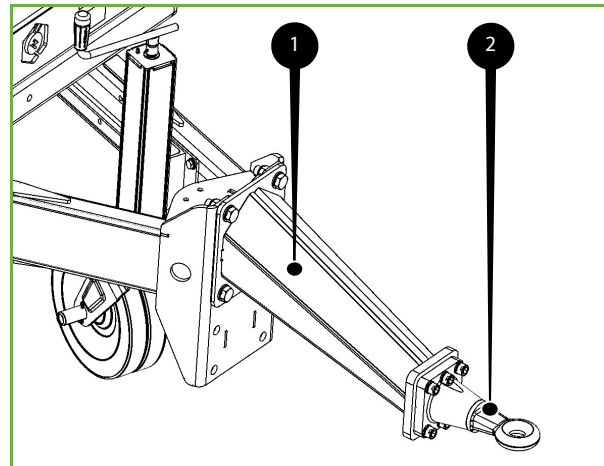

Figure 2-12: Fixed drawbar (non-braked)

- 1 - Fixed drawbar
- 2 - Pivotable drawbar eye

- **Overrun brake**

The tipping trailer may be equipped with an overrun brake. Please refer to *Figure 2-13*.



OBSERVATION:

The overrun brake consists of a special drawbar with a fixed drawbar eye and must therefore be connected to the pivotable upper drawbar.

The overrun brake is attached to the brake levers on the axle by means of steel cables. The wheels are fitted with drum brakes. The axle incorporates a safety feature to ensure that braking does not occur while reversing.

The Z030, Z045 and Z050 models of the tipping trailer can be equipped with an overrun brake.

- 1 - Handbrake
- 2 - Drawbar eye with overrun brake

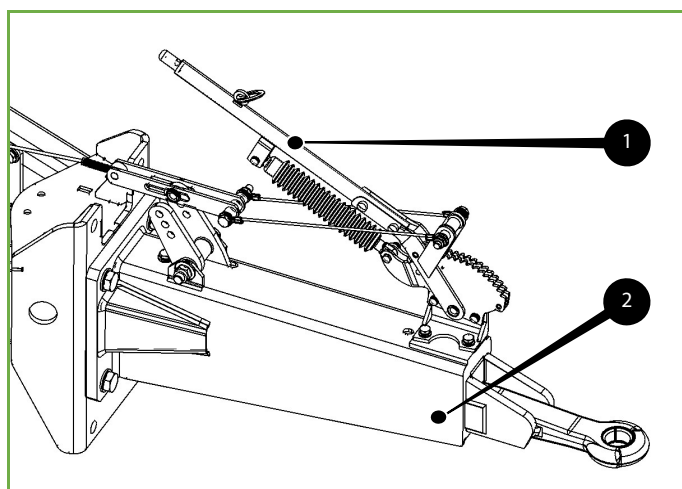

Figure 2-13: overrun brake

Use of an overrun brake is permitted up to a maximum total weight of 8,000 kg. If the total weight exceeds 8,000 kg, a hydraulic or pneumatic braking system must be used.

Tipping trailers equipped with an overrun brake are permitted on public roads up to a maximum speed of 40 km/h.

The overrun brake also functions as a handbrake; the handbrake of the tipping trailer is operated by means of the handbrake lever.

The handbrake of the tipping trailer operates automatically in the event of the tipping trailer breaking out. The break-out safety cord activates the handbrake if a break-out occurs, after which the cord snaps.

- **Hydraulic braking system (1-circuit)**

The Z080 and Z100 models of the trailer are fitted with a hydraulic (1-circuit) braking system **as standard**.

Please refer to

Table 2-2 for other options.

- 1 - Hydraulic hose for tipping
- 2 - Hydraulic brake circuit, 1-circuit system

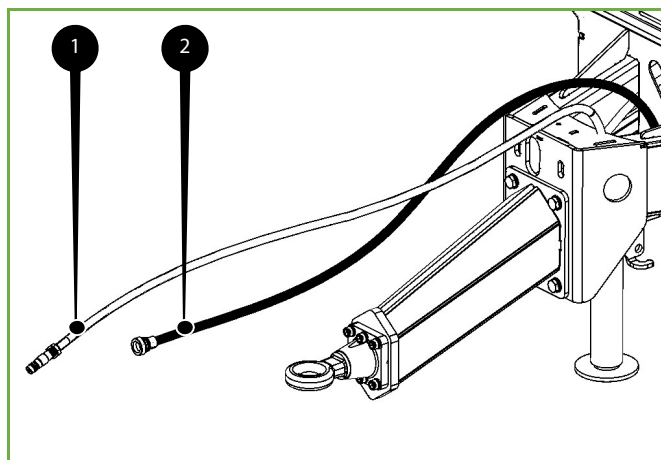

Figure 2-14: Hydraulic brake connection (1-circuit)

The tipping trailer is fitted with a hydraulically braked axle with a single hydraulic brake circuit as standard. The brake is engaged when the tractor driver operates the foot brake.

The use of a single hydraulic brake circuit is no longer permitted in a number of European countries. Consequently, tipping trailers fitted with such a braking system will not be approved for EU registration.

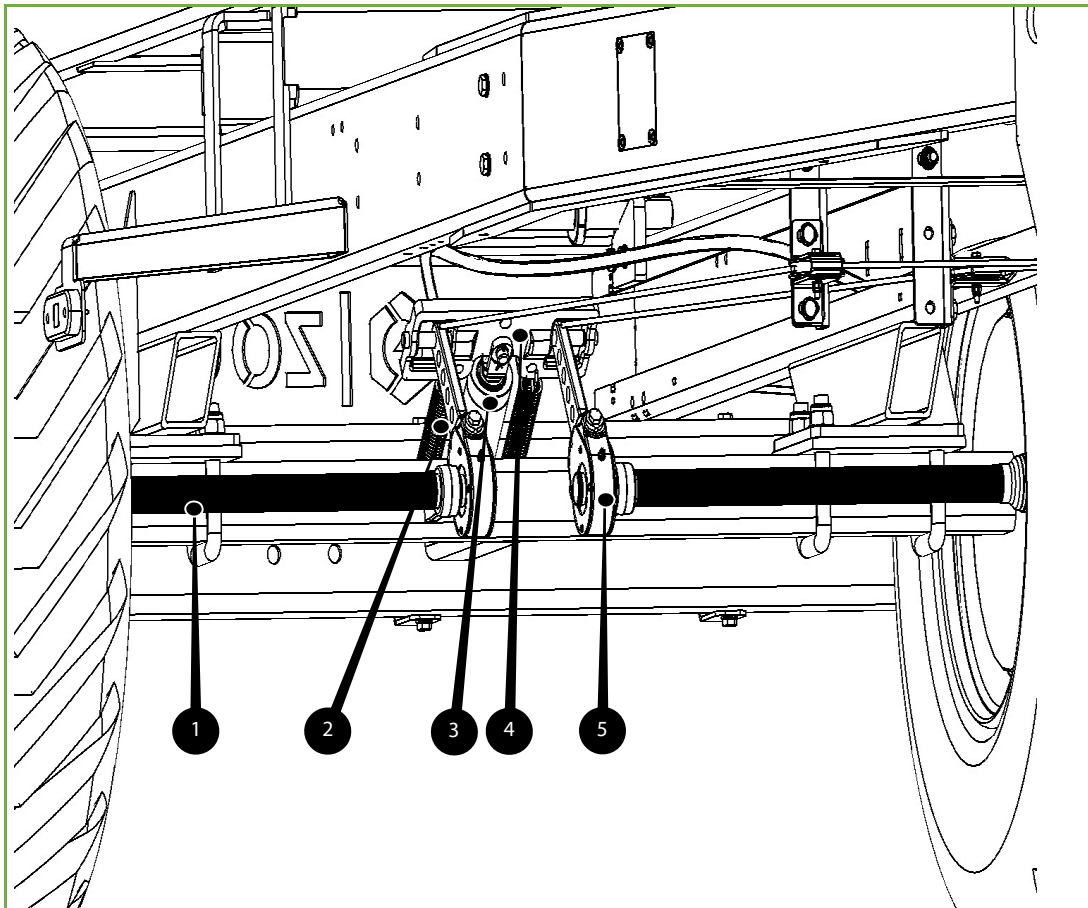

Figure 2-15: Hydraulic braking system (single axle, non-spring-loaded)

- 1 - Brake rod
- 2 - Double draw-spring (to release brakes)
- 3 - Brake cylinder (hydraulic)
- 4 - Braking power regulator (also fixation of overrun brake / handbrake)
- 5 - Brake lever (2 x)

The brakes are controlled by a braking power regulator [4] which is engaged by a pneumatic or hydraulic brake cylinder. The wheel brakes are operated by mean of brake levers [5] and brake rods [1].

- **Hydraulic braking system (2-circuit)**

The tipping trailer can be fitted with a hydraulically braked axle controlled by a hydraulic 2-circuit braking system. This system meets EU requirements.

In addition to the normal braking function, the system includes a supply circuit that controls the system. If the tipping trailer should unexpectedly break away from the tractor, the pressure in the supply line is cut off. The system then directs the oil pressure from the accumulator to the brakes and the tipping trailer is stopped by the emergency brake. Please refer to *Figure 2-17*.

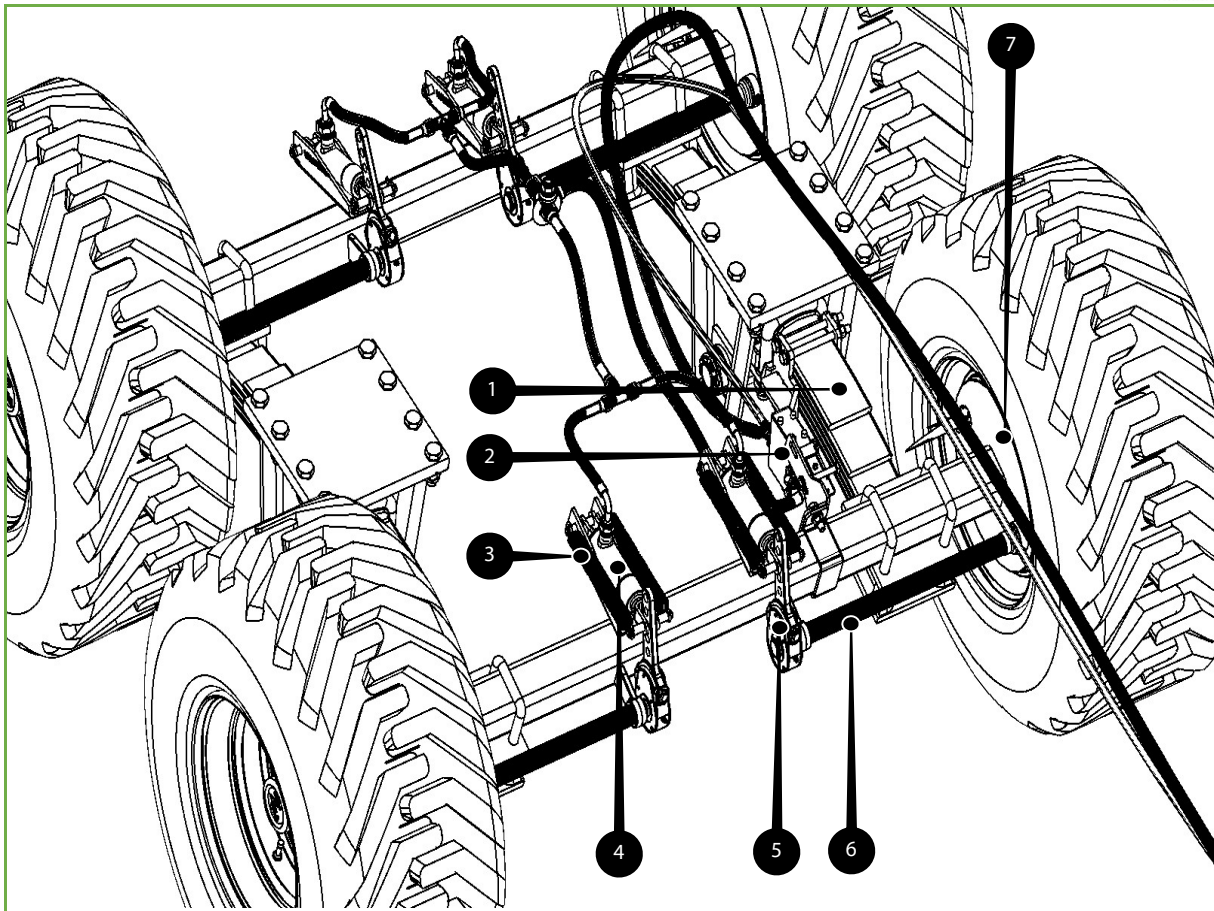

Figure 2-16: Hydraulic braking system (spring-loaded tandem axle)

- 1 - Spring-leaf package
- 2 - ALR valve
- 3 - Brake spring
- 4 - Brake cylinder
- 5 - Brake lever
- 6 - Brake rod
- 7 - Brake drum

- **Hydraulically braked, with hand-operated braking power control (2-circuit)**

Under EU legislation, the maximum speed of tipping trailers equipped with hand-operated braking power controls is limited to 30 km/h. A hand-operated braking power control may only be fitted to tipping trailers without spring-loaded axles. The 4-position valve must be manually adjusted after loading and unloading according to the load. The degrees of loading are: 1/3 full, 2/3 full or fully loaded. Please refer to *Figure 2-18*.

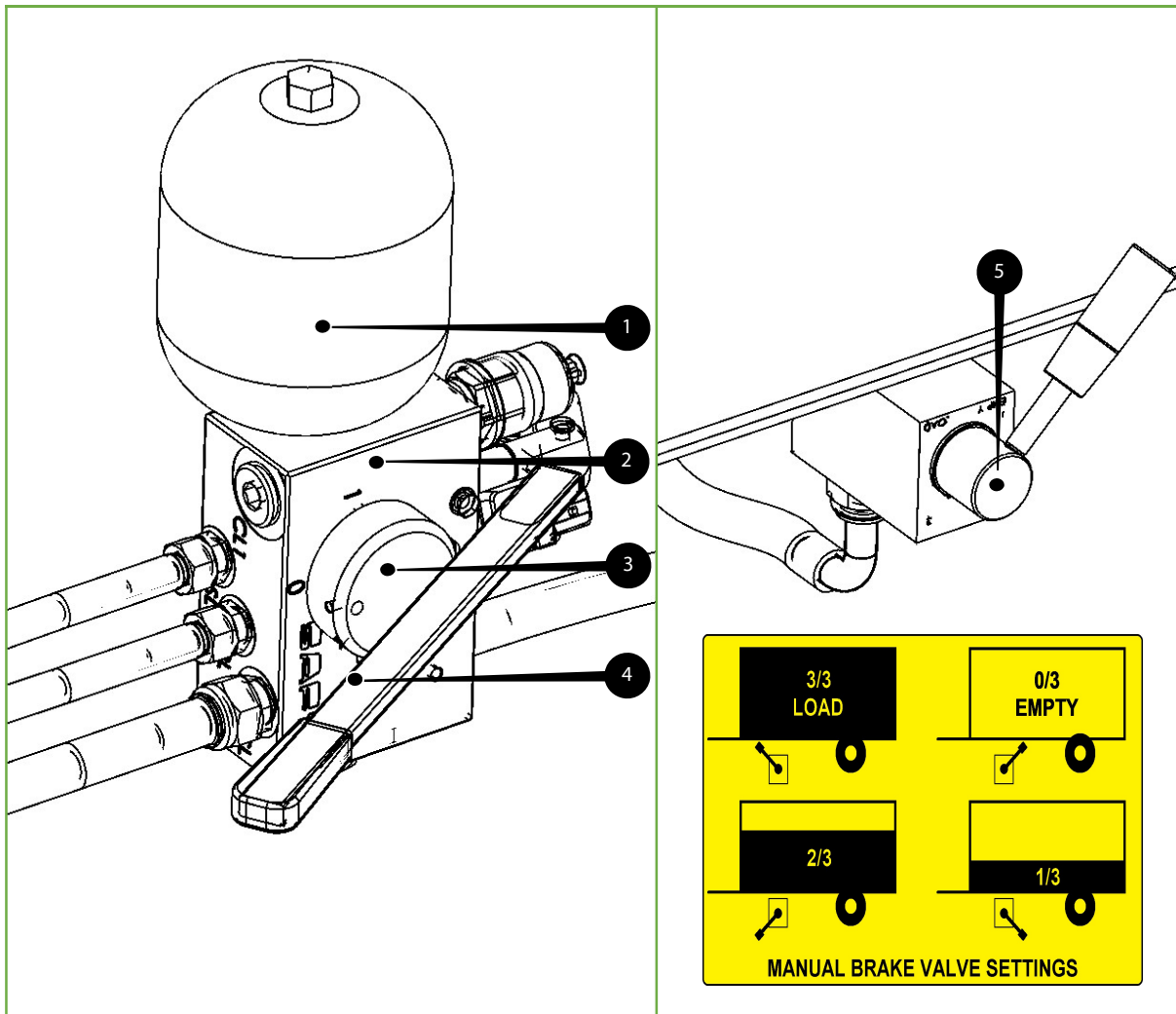

Figure 2-17: Hydraulic brake valve

Figure 2-18: 4-position handle (degree of loading)

- 1 - Accumulator
- 2 - Manifold block for 2-circuit hydraulic valve
- 3 - Selection switch for 1-circuit or 2-circuit system
- 4 - Oil pump lever (to depressurise the circuit)
- 5 - Loading degree handle (4 positions)

- **Hydraulically braked, with automatic braking power control (2-circuit)**

The tipping trailer can be fitted with a hydraulically braked axle controlled by a hydraulic 2-circuit braking system. This system meets EU requirements.

In addition to the normal braking function, the system includes a supply circuit that controls the system. If the tipping trailer should unexpectedly break away from the tractor, the pressure in the supply line will be cut off. The system will then direct the oil pressure from the accumulator to the brakes and the tipping trailer will be stopped by the emergency brake.

An automatic load-dependent braking power control (ALR) automatically adjusts the braking power to the load. The valve is controlled according to the weight of the load as exerted on the spring-loaded axles (only applies to spring-loaded tandem axle).

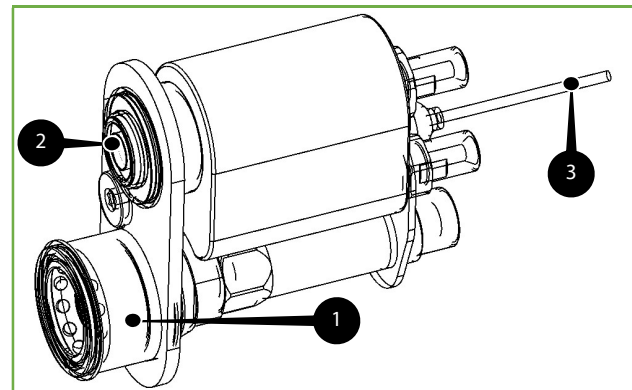

Figure 2-19: Connections of 2-circuit system

- 1 - Coupling - main brake circuit
- 2 - Coupling - supply circuit
- 3 - Steel break-out safety cable (for 1-circuit operation)

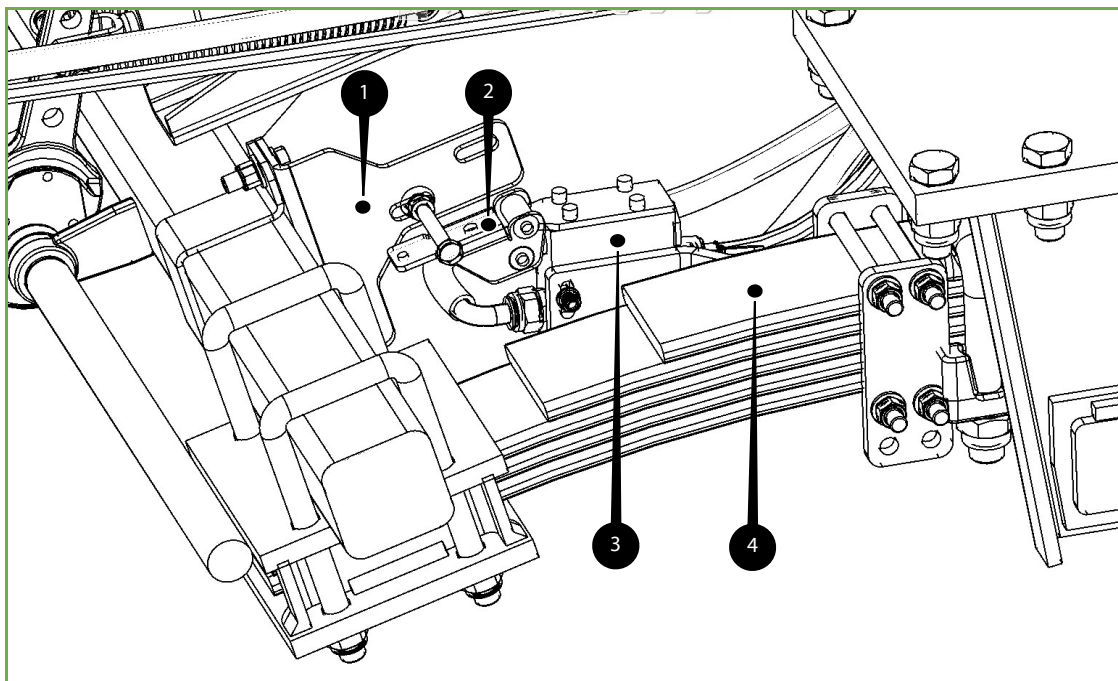

Figure 2-20: Automatic load-dependent braking power control (ALR; hydraulic)

- 1 - Axle position handle
- 2 - ALR valve control handle
- 3 - ALR valve
- 4 - Spring-leaf package

- **Pneumatic braking with hand-operated braking power control (2-circuit)**

The tipping trailer can be fitted with a pneumatically braked axle controlled by a pneumatic 2-circuit braking system. This system meets EU requirements.

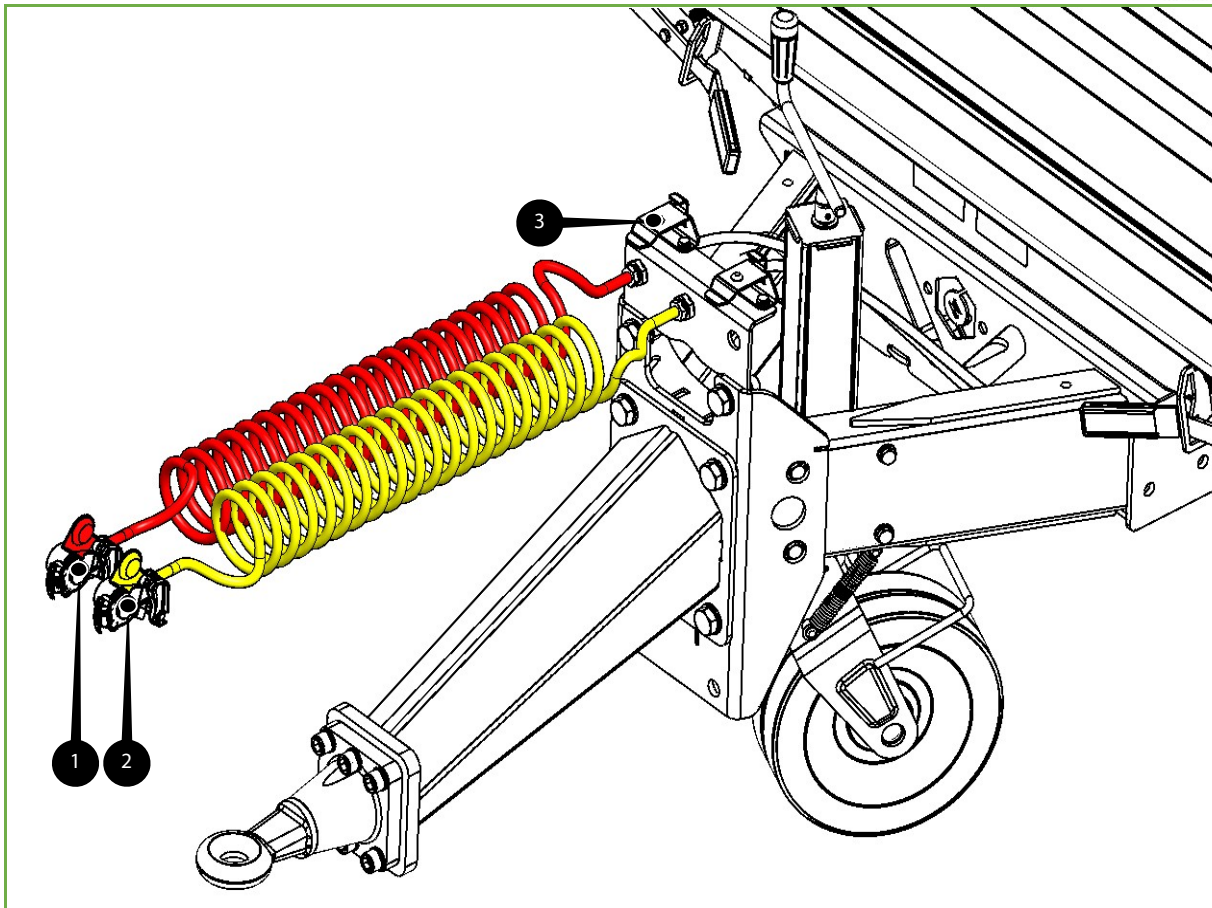

Figure 2-21: Pneumatic brake connections

- 1 - Supply line (red, towards air vessel)
- 2 - Brake line (yellow)
- 3 - Dummy coupling hose support

The pneumatic braking system includes a control function which becomes operative when the pressure in the supply line [3] is cut off. In the event of the tipping trailer breaking out, the couplings are detached and the pressure in the circuits is cut off. The air from the air vessel will then be directed to the brakes so that the tipping trailer is stopped by the emergency brake.

A hand-operated braking power control [1] is available to ensure that the braking power is appropriate for the load. Please refer to *Figure 2-22*. The selection handle must be adjusted according to the load; empty, 1/2 full or fully loaded. A quick discharge valve [5] ensures that the brakes are released quickly.

The speed of tipping trailers fitted with a hand-operated braking power control is limited to 30 km/h by EU legislation.

Only tipping trailers without spring-loaded axles can be fitted with a hand-operated braking power control.

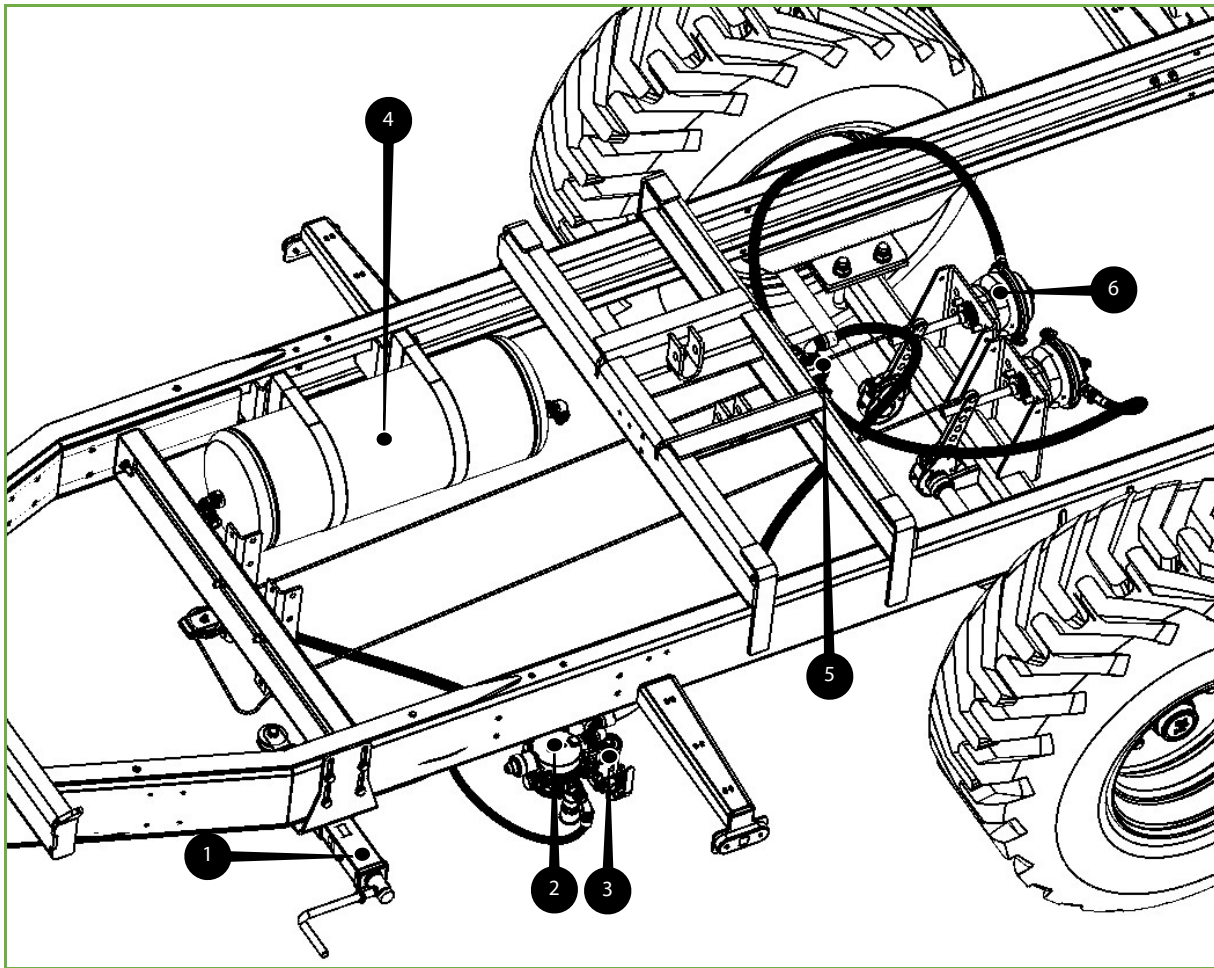

Figure 2-22: Pneumatic hand-operated braking power control

- 1- Handbrake
- 2- Pneumatic valve block
- 3- Braking power control
- 4- Air vessel
- 5- Quick discharge valve
- 6- Brake booster

- **Pneumatic braking with automatic braking power control (2-circuit)**

(For spring-loaded tandem axle only)

The tipping trailer can be fitted with a pneumatically braked axle controlled by a pneumatic 2-circuit braking system. The brake levers are then controlled by pneumatic brake boosters [6]. This system meets EU requirements.

The pneumatic braking system includes a supply line that controls the system. In the event of the tipping trailer breaking out, the pressure in the supply line will be cut off. The air from the air vessel will then be directed to the brakes and the tipping trailer will be stopped by the emergency brake. An automatic load-dependent braking power control [4] is fitted which automatically adjusts the braking power to the load. It controls the pressure in the brake boosters [6] and is operated by the control arm [5] according to the weight of the load on the spring-loaded axles.

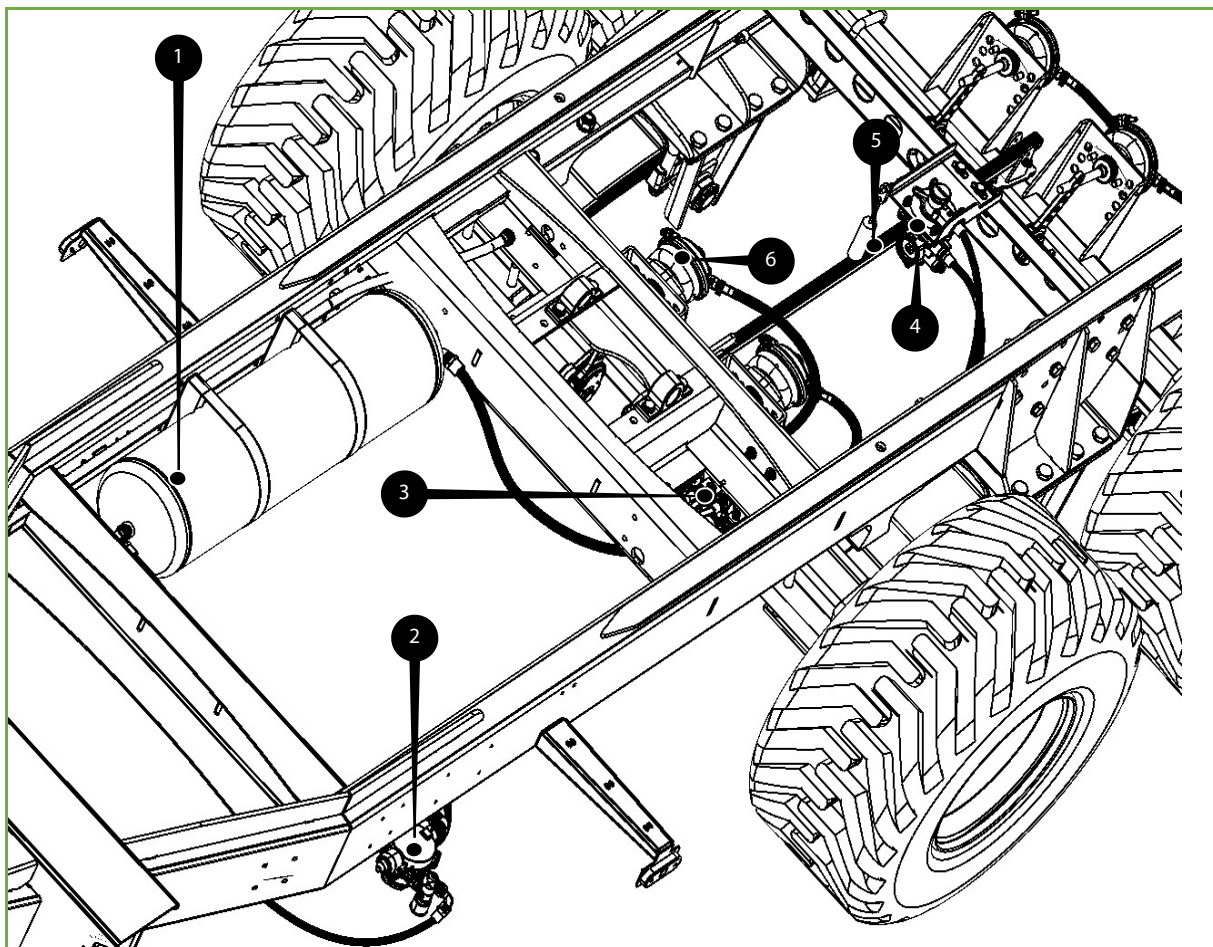

Figure 2-23: Automatic load-dependent braking power control (ALR, pneumatic)

- 1 - Air vessel
- 2 - Brake valve
- 3 - Relay valve
- 4 - ALR valve
- 5 - ALR valve control arm
- 6 - Brake booster

3. SAFETY

3.1 General Safety Instructions



WARNING:

Always ensure that nobody is within the unfolding zone of the machine before unlocking the hooks.

Always comply with the following points (if applicable).

- Only use the machine for the purpose for which it has been designed.
- Operate the machine in a safe manner.
- Keep safety signs in a good state of repair and replace any missing or damaged signs.
- Keep well clear of any turning and pivoting components.
- Stay away from the area between the tractor and the tipping trailer when the tractor is in operation.
- Ensure that there is nobody within the machine's range of operation.
- Carry out the daily check before driving off. Please refer to paragraph 8.3.3.
- Follow the prevailing legal regulations when driving on public roads. Please refer to paragraph 2.3.7.
- Use flashing lights or other warning signs as necessary.
- Make sure that sufficient weight is exerted on the tractor's front axle.
- The tipping trailer should only be loaded when it is coupled to a tractor.
- Monitor the load exerted on the drawbar during loading. The manner of loading can greatly impact the bearing pressure on the tow bar. This also applies to spreading the load evenly across the body of the tipping trailer.
- It is prohibited to load the tipping trailer in excess of the maximum permitted loading capacity.
- Do not stack the load too high when driving on rough or sloping ground; to do so will make the tipping trailer unstable and liable to topple over.
- Keep away from overhead power lines.
- In the event of a thunderstorm, stay inside the tractor cabin to avoid the danger of being struck by lightning.
- It is prohibited to drive the trailer with the body tipped.
- The transporting of people on the drawbar or in the body of the trailer is strictly forbidden.
- Always secure the tipping trailer with the handbrake when uncoupling it. You can also block the wheels to prevent the trailer from rolling off.

- Wear safety shoes when working on the tipping trailer; changing tyres, handling extensions etc.
- Do not pump up the tyres to an excessive pressure. Please refer to *Table 8-1* for the correct tyre pressures.
- Avoid driving over sharp objects due to the risk of a blowout.

3.2 Warning symbols

There are warning stickers at several locations on the tipping trailer alerting the user to:

- potential dangers;
- correct (safe) control.



ATTENTION:

Make sure that these stickers remain legible at all times. Replace any damaged or illegible stickers.

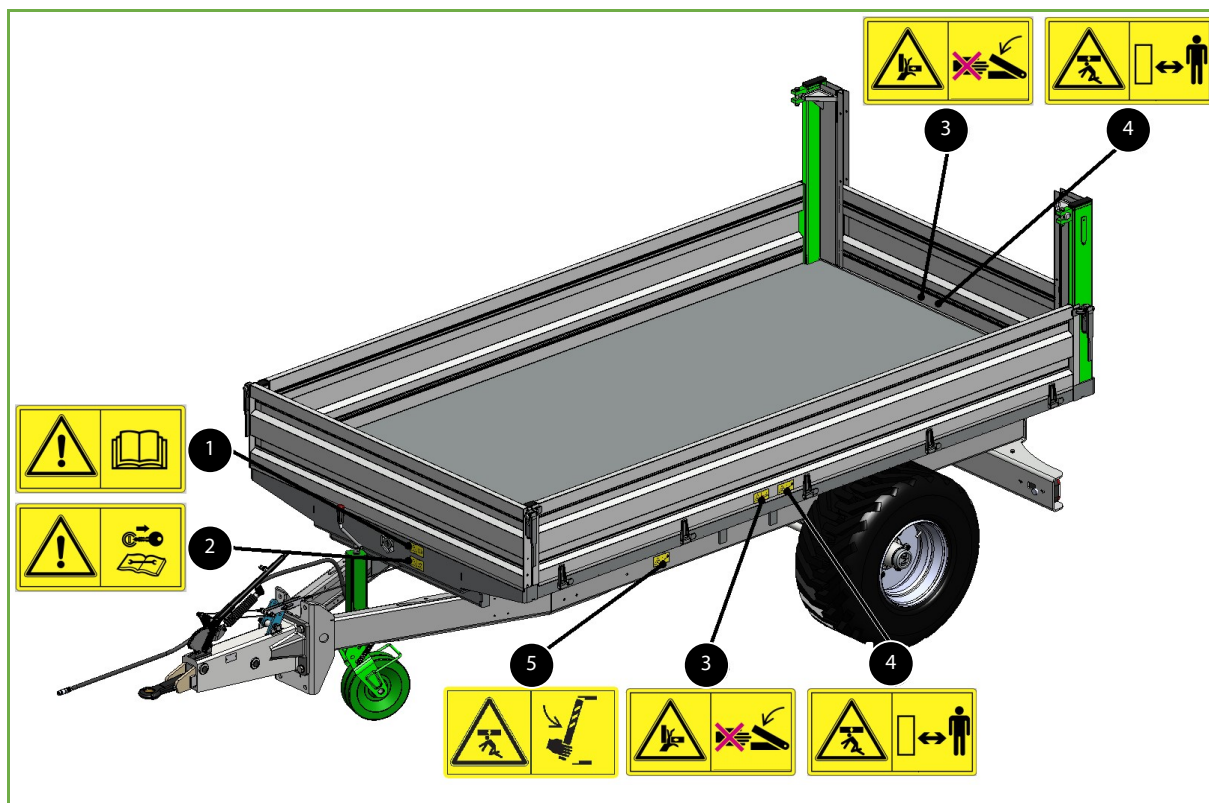

Figure 3-1: Location of stickers

- 1 - Attention: Read the manual
- 2 - Attention: Maintenance work
- 3 - Danger: Risk of pinching
- 4 - Danger: Falling parts
- 5 - Danger: Use mechanical safety bar

3.2.1 Safety stickers

	<p>ATTENTION: Make sure that the stickers remain legible at all times. Replace any damaged or illegible stickers.</p>
	<p>ATTENTION: Read the Operating Manual Read the Operating Manual before use.</p>
	<p>ATTENTION: Maintenance work Switch off the motor and remove the ignition key before carrying out maintenance or repairs to the machine.</p>
	<p>DANGER: Risk of pinching Keep clear of the danger zone of pivoting components.</p>
	<p>DANGER: Falling components Stay clear of the danger zone. Risk of falling objects.</p>
	<p>DANGER: Use mechanical safety bar Stay clear of the danger zone. Install the safety bar before entering the area underneath a raised body.</p>

Figure 3-2: Safety stickers

4. CHECKS BEFORE DRIVING OFF

Check the following points before driving off and make sure you comply with all of them.

- The lights work.
- The side and rear boards are secured.
- The tyre pressures are correct.
- The handbrake is fully released.
- All hoses are connected and the tractor's hydraulic and pneumatic controls are in the correct position.
- The brakes function correctly.
- The accumulator for hydraulic brakes is filled, if applicable. In that case, apply the brake forcefully three times before driving off.
- The break-out safety cord is coupled to the tractor, if applicable.
- The cargo is secure, and covered by a net or tarpaulin to prevent any loss, if applicable.
- Never drive faster than the specified maximum permitted technical speed if this is lower than the maximum statutory permitted speed on public roads.

4.1 Dimensions

Please refer to *Table 2-1* or

Table 2-2 for the dimensions of the various types of tipping trailer.



OBSERVATION:

The height of the tipping trailer must not exceed 4 m on public roads.

5. OPERATION

5.1 Rear tailgate

The tipping trailer is fitted with raised supports for the rear tailgate as standard. The tail board pivots at the top of the supports and is secured automatically or hydraulically at the lower edge when closed.

The rear tailgate can be equipped with folding doors as an option. Please refer to paragraph 5.1.3. If folding doors are fitted, the base of the rear tailgate is then locked manually.

5.1.1 Rear tailgate locking hooks

The rear tailgate of models Z030, Z045 and Z050 is fitted with an automatic locking system as standard. The rear tailgate is automatically secured by locking hooks when the body is lowered [1].

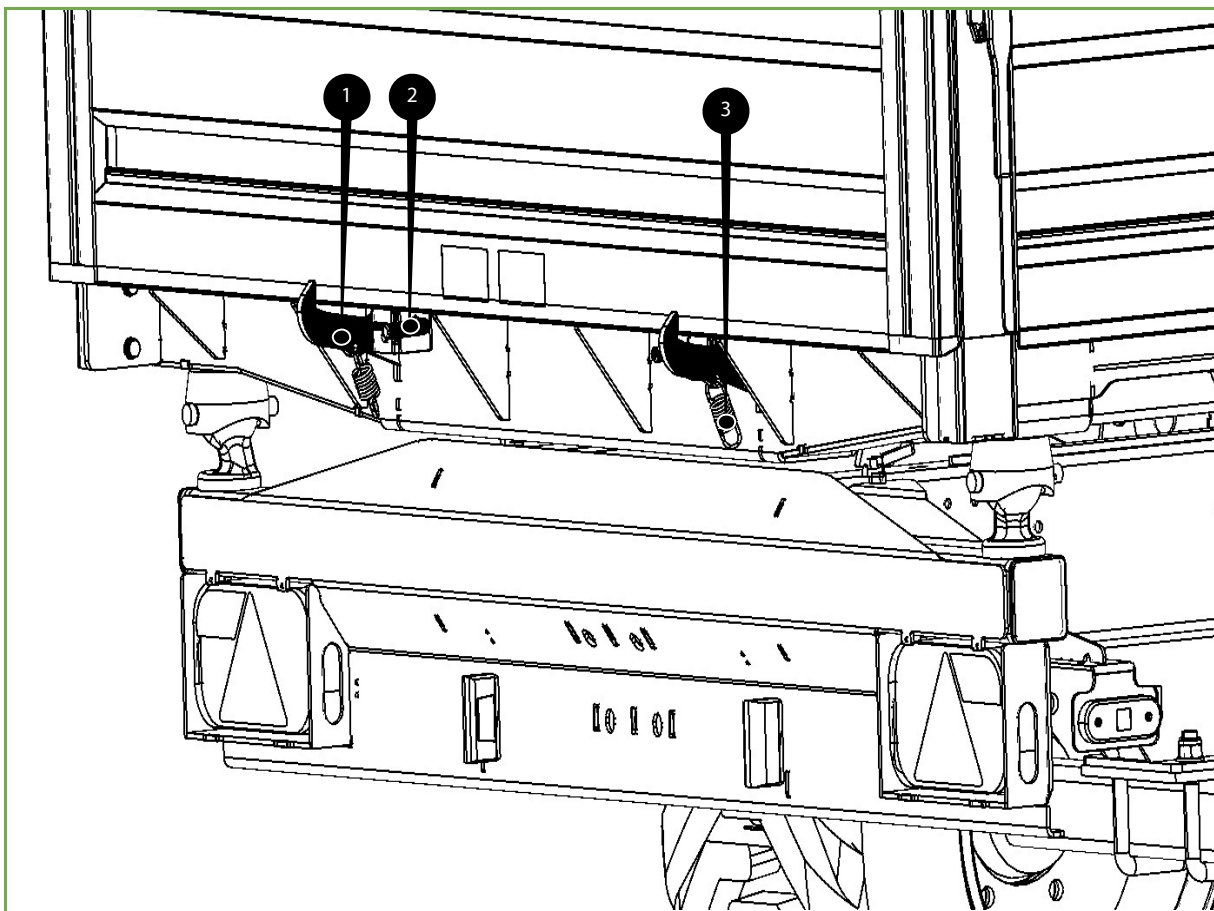

Figure 5-1: Rear tailgate locking hooks

- 1 - Rear tailgate locking hook (2 x)
- 2 - Locking hook bolt (Z030/Z050)
- 3 - Locking hook draw-spring

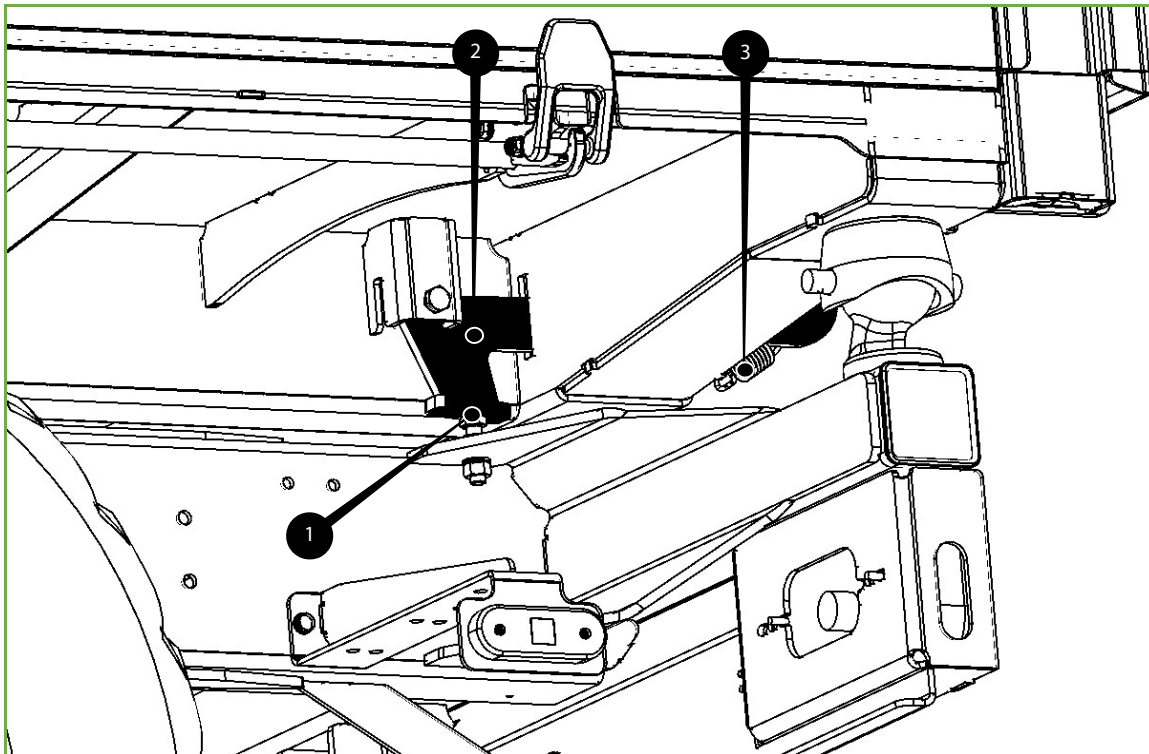

Figure 5-2: Detail of rear tailgate locking hook

- 1 - Stop bolt
- 2 - Rear tailgate locking hook
- 3 - Draw-spring

When the body is lowered, the locking hooks [2] are automatically pushed upwards by the stop bolts [1]. The locking hooks secure the lower edge of the rear tailgate [4] during transport.

The locking hooks release automatically when the body is lifted. The draw-springs [3] unhook the securing hooks upon the release of the stop bolts.

5.1.2 Hydraulic rear gate locking

The Z080 and Z100 tipping trailers are fitted with a hydraulic locking system for the rear tailgate as standard.

This system is operated from the tractor.

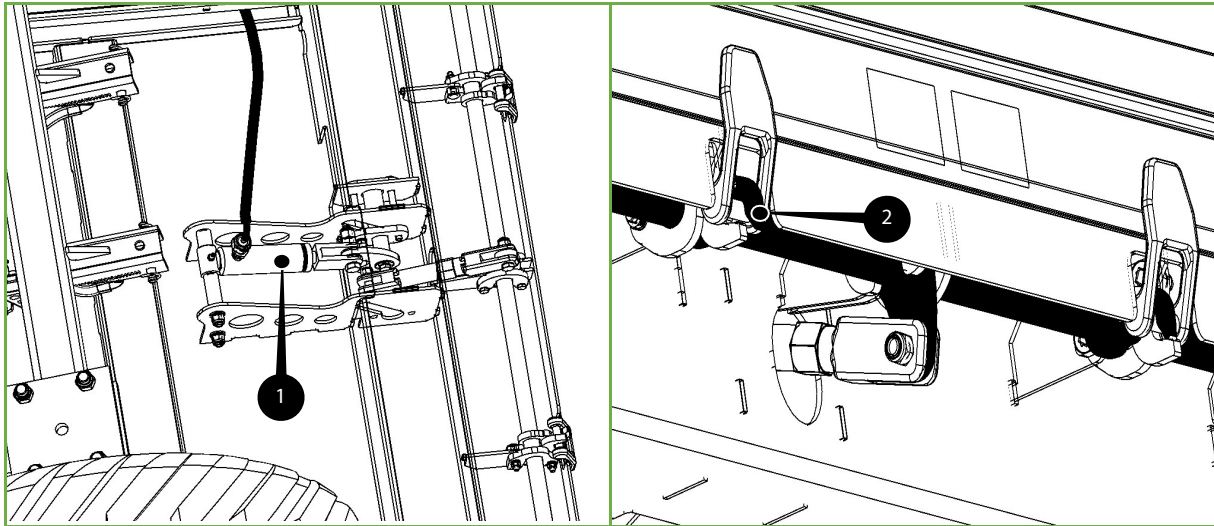

Figure 5-3: Hydraulic rear tailgate locking

Figure 5-4: Locking hook system

- 1 - Hydraulic locking ram
- 2 - Rear tailgate locking hook

5.1.3 Folding doors

The folding doors can be left open for the transport of long cargoes, or if a forklift truck is used to load the tipping trailer from the rear. Please refer to *Figure 2-9*.

The tipping trailer can normally be discharged rearwards provided that:

- the lock between the board halves [1] is secured
- the locking hooks on the lower edge [2] have been released.
- The board will then pivot on the top hinges

For sideways tilting, the rear tailgate must be secured so that it remains closed. To secure the rear tailgate, the locking pin must be inserted into the hole in the locking hook [2] while the body is at its lowest position.

5.1.4 Operation of locking hooks on use of folding of doors

The locking hooks [1] of the rear tailgate are retracted by a spring [2] when the locking pin [3] is removed. As the body descends, the locking hooks are brought into the securing position after which they are secured by the pins.

- 1 - Locking hook
- 2 - Draw-spring
- 3 - Locking pin

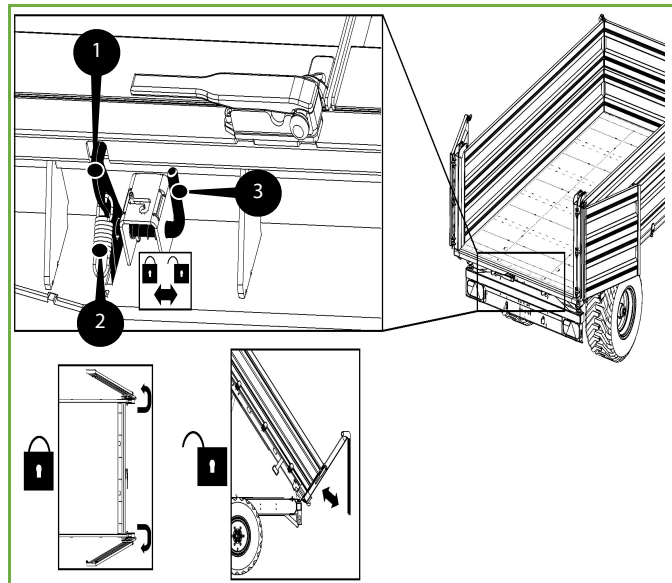

Figure 5-5: Securing of the Z030/Z050 rear tailgate

5.2 Side boards

The tipping trailer is fitted with side boards that fold down on fixed lower hinges as standard.

If the sideways tipping option is selected, the side boards are designed to pivot on top hinges [4] or can be folded down using the lower hinges. Please refer to Figure 5-6.

- 1 - Pivoting point for tilting (left front ball)
- 2 - Side board locking handle
- 3 - Top side lock/side board hinge
- 4 - Side board top hinge
- 5 - Side board

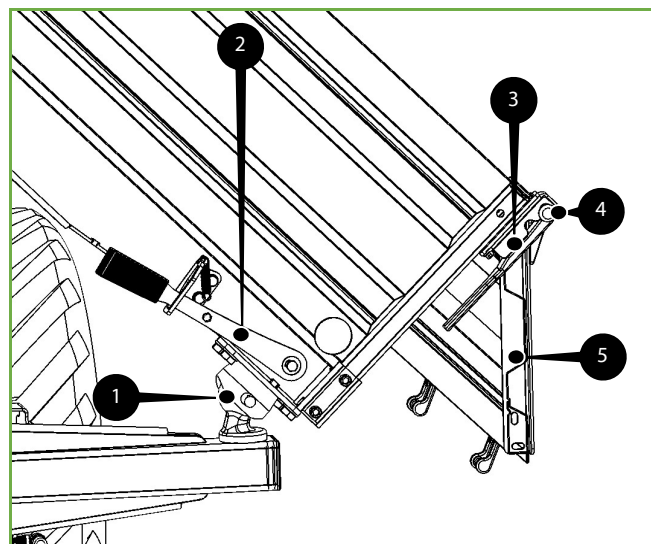

Figure 5-6: Sideways tipping

5.2.1 Manual locking of the side boards

The side boards are locked by means of a handle [3] which activates the locks [1] with a locking rod [2].

If the locking system is in operation, the side board can be folded down providing that the top lock [4] has been unlocked. The locking hooks [1] then form part of the pivoting point.

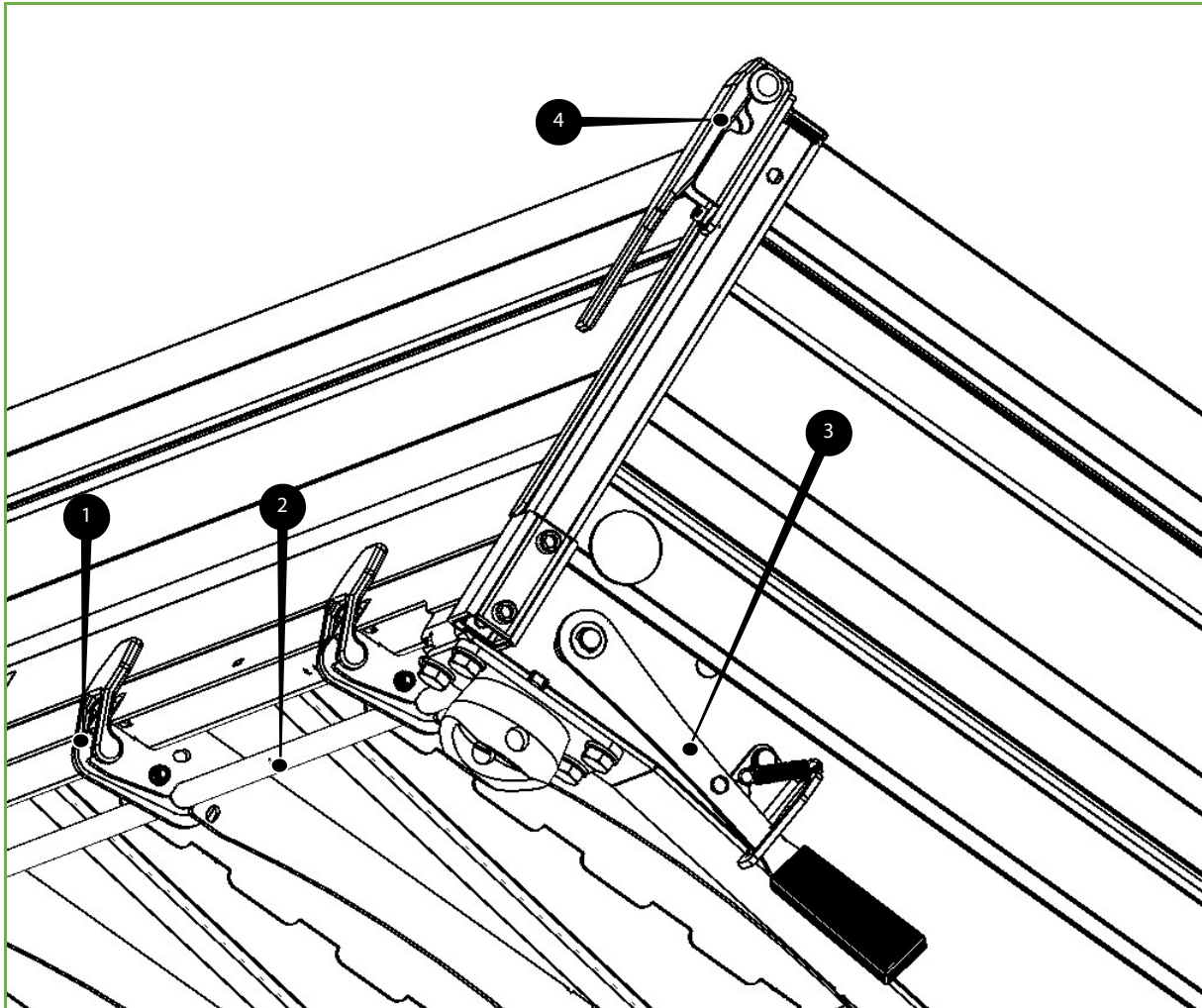

Figure 5-7: Securing the side boards

- 1- Locking hook
- 2- Locking rod
- 3- Side board locking handle
- 4- Top side lock/side board hinge

5.2.2 Hydraulic side board locking

The side boards of models Z080 and Z100 are secured hydraulically.

Using the selection handle [7] the operator can choose between forward and sideways tipping. The direction of tipping is selected by means of the selection handle [6]. A choice can be made between tipping to the left or right. The cylinder [4] makes an intermediate mechanism turn, which controls the locks [3] by means of a locking rod [2].

The locks [3] can be manually secured by means of the handle [1] when the hydraulic hoses [5] are depressurised.

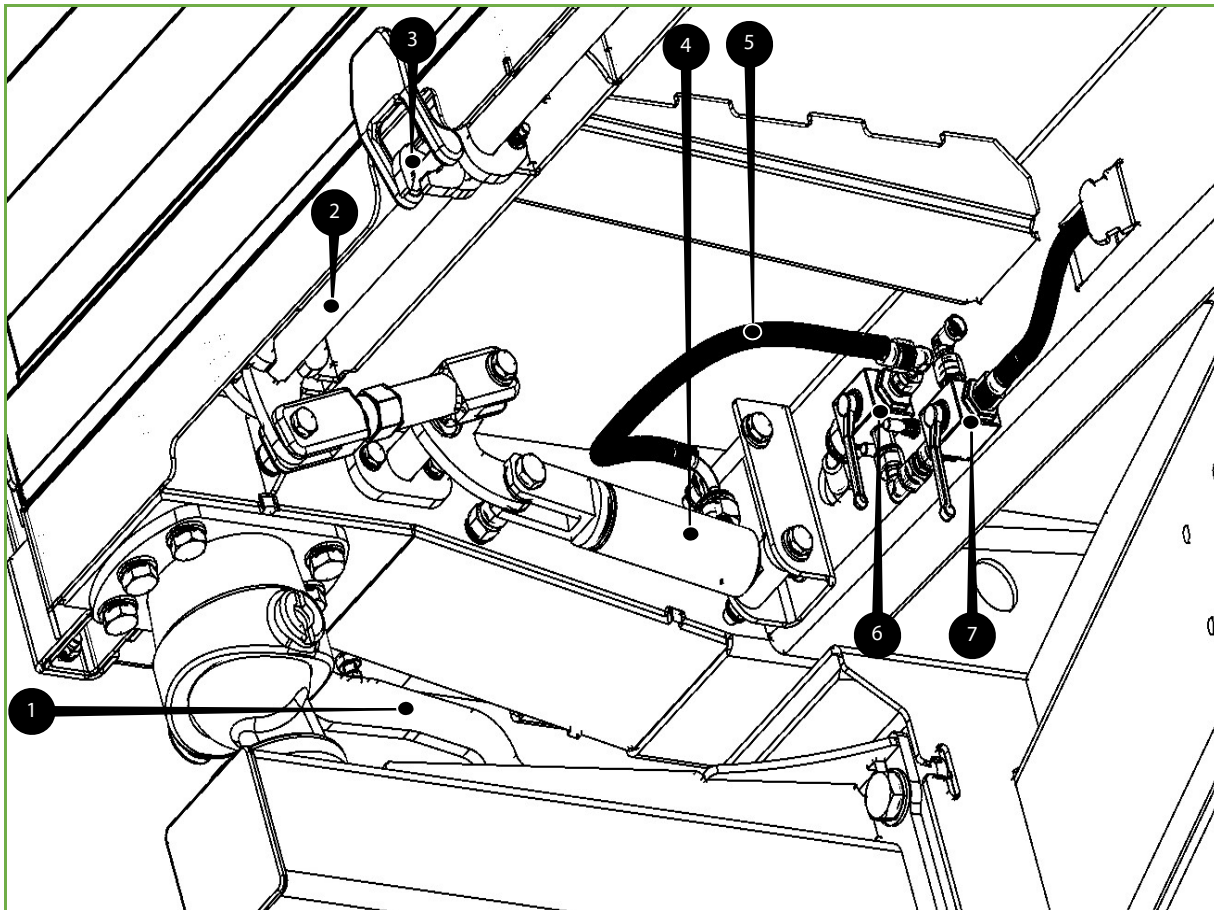

Figure 5-8: Hydraulic side board locking

- 1 - Manual locking handle
- 2 - Lock
- 3 - Locking rod
- 4 - Locking ram (spring return)
- 5 - Hydraulic hoses
- 6 - Side board selection handle: locking on the left or right
- 7 - Selection handle for locking at the rear or left/right

5.3 Braking system

The wheel brakes are operated by a brake rod [1] actuated by a brake lever [2]. The brake lever can be controlled mechanically by means of a brake cable (overrun brake), hydraulically by means of a brake cylinder, or pneumatically by means of a brake booster. The handbrake is connected to the brake levers by means of brake cables to put the tipping trailer in the handbrake position. In the event of breaking out of the trailer, the break-out safety cable will pull the handbrake, which will automatically operate the trailer's emergency brake.

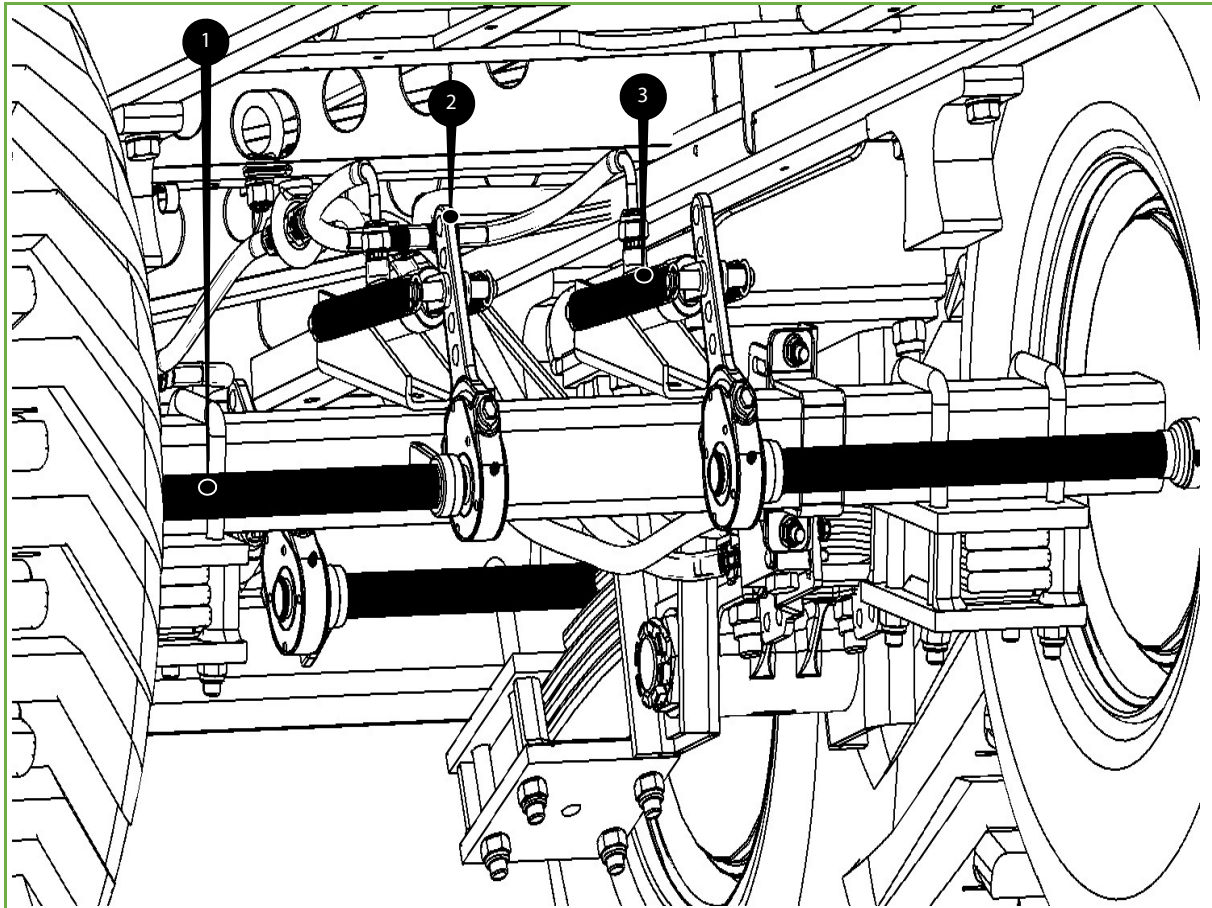

Figure 5-9: Hydraulic brake system (tandem axle)

- 1 - Brake rod (on each wheel)
- 2 - Brake lever
- 3 - Double spring (brake discharge)

5.3.1 Overrun brake

The overrun brake system slows down the tipping trailer by the braking of the tractor and the pushing (overrunning) of the tipping trailer. The overrun brake ensures that the brake cable [1] is pulled through a lever on the drawbar when the drawbar eye [3] is pushed in.

The brake cable [1] is also pulled when the handbrake [2] is operated.

This braking system includes a single hydraulic tipping hose, which is connected to the tractor.

- 1 - Brake cable
- 2 - Handbrake
- 3 - Overrun brake drawbar eye

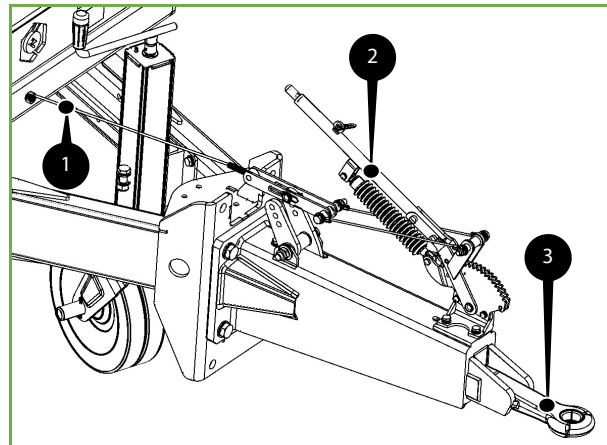

Figure 5-10: Overrun brake

The handbrake lever incorporates a gas spring which keeps the handbrake under constant pressure. There is a possibility that the handbrake may further tighten itself slightly when the tipping trailer is moved.

The break-out safety cord of the handbrake must be attached to the tractor. In the event of the breaking out of the tipping trailer, the cord tightens the handbrake and will operate the tipping trailer's emergency brake before it snaps.

The maximum permissible weight for trailers with an overrun brake is 8,000 kg. The use of an overrun brake is therefore not permitted on the Z080 and Z100 models and these must be fitted with hydraulically or pneumatically operated brakes.

There is a system that puts the brake out of operation to enable reversing. It will only change over on the application of a certain push force, whereby the handbrake function remains largely secured.

Always secure the tipping trailer with the handbrake when uncoupling the vehicle.



OBSERVATION:

Never park the tipping trailer on a slope with the drawbar facing upwards. You can also block the wheels as a precaution to prevent rolling.

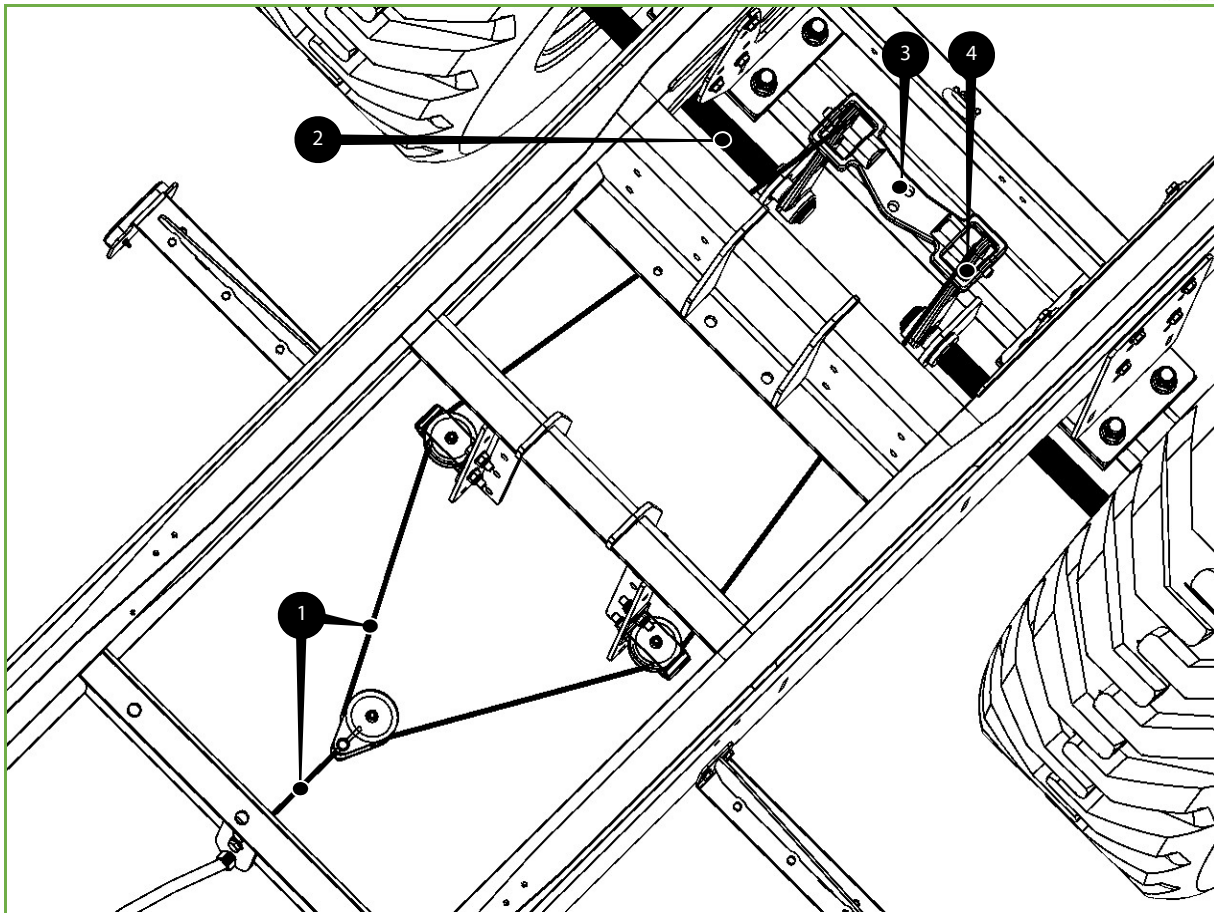

Figure 5-11: Overrun braking system

- 1 - Brake cable
- 2 - Brake rod
- 3 - Brake force regulator
- 4 - Brake lever

The brake levers [4] are tightened when the brake cable [1] is pulled, either via the brake force regulator [3] or directly by the brake levers. The brake is actuated upon the turning of the brake rod [2].

5.3.2 Hydraulic braking system (1-circuit)

This braking system consists of a single hydraulic circuit connected to the tractor. The hose becomes pressurised when the brake is applied on the tractor. The other hydraulic hose is part of the mechanism for tipping the body.

- 1 - Hydraulic hose for tipping
- 2 - Hydraulic line for braking

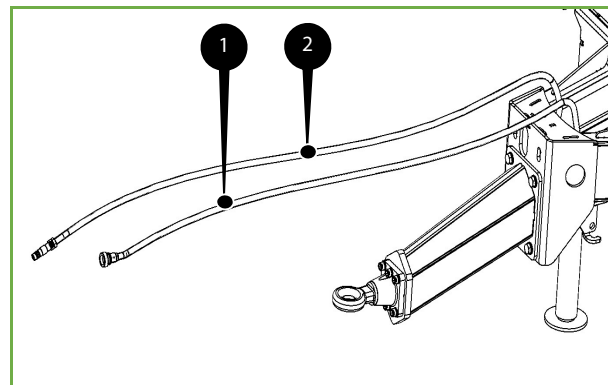

Figure 5-12: Hydraulic lines of 1-circuit system

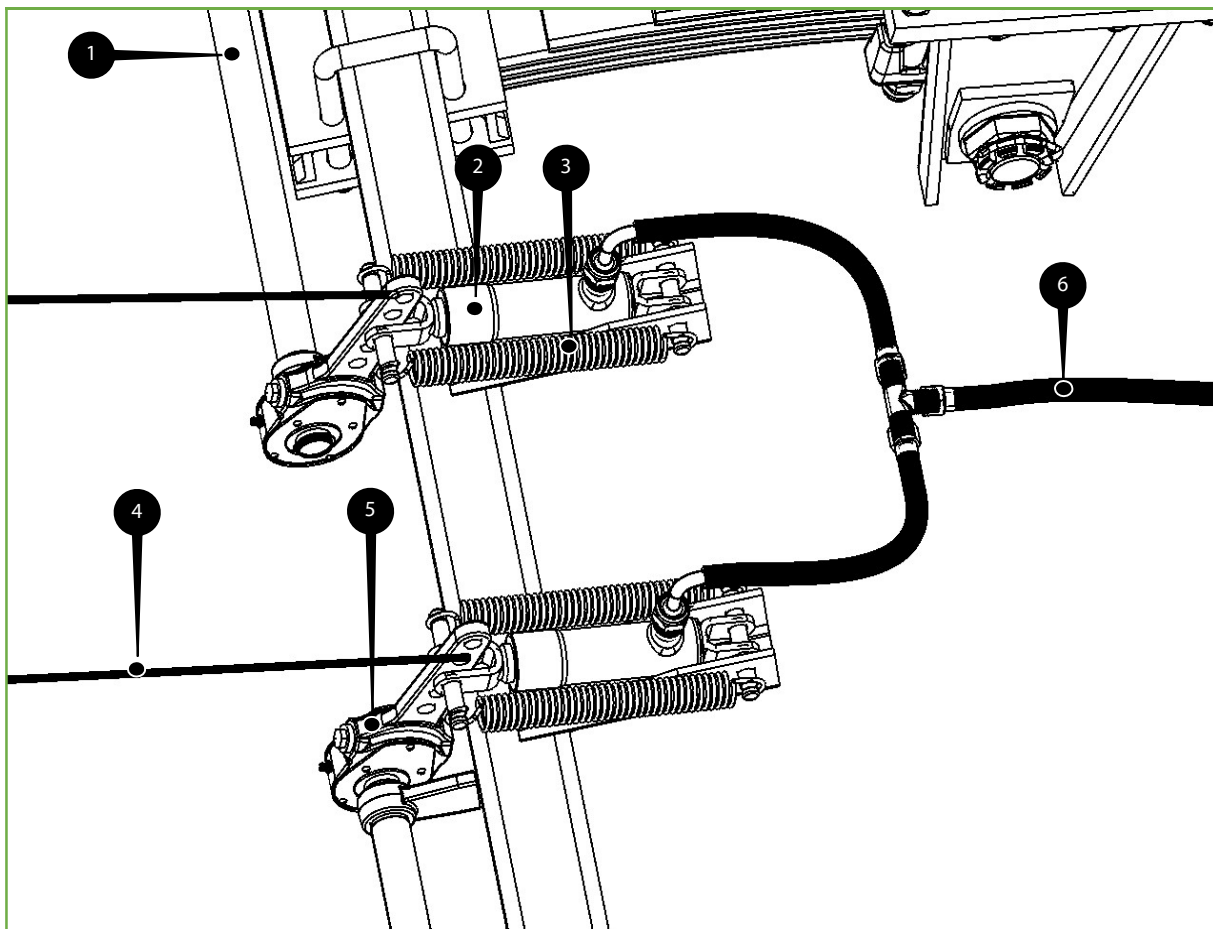

Figure 5-13: Braking system

- 1 - Brake rod (towards drum brake)
- 2 - Brake cylinder
- 3 - Double spring (brake discharge)
- 4 - Handbrake cable
- 5 - Brake lever
- 6 - Hydraulic brake circuit

The brake cylinders [2] push the brake levers [5] forwards to operate the brake. The brake cables [4] of the handbrake pull the brake levers [5].

After the braking operation, the brakes are released by the double springs [3] which retract the cylinder.

5.3.3 Hydraulic braking system (2-circuit)

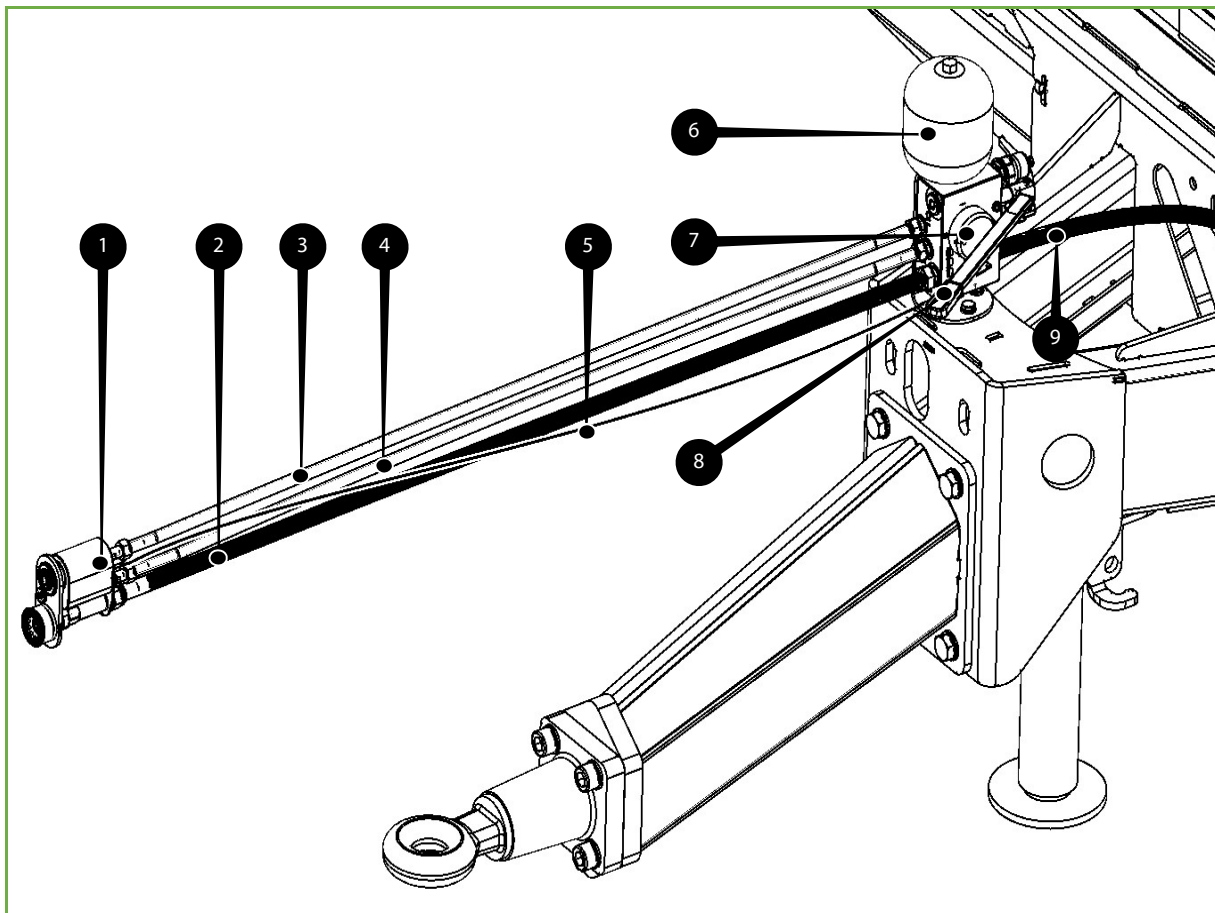

Figure 5-14: Components of 2-circuit system

- 1 - Double coupling including brake and control lines
- 2 - Main brake line
- 3 - Supply line
- 4 - Return line
- 5 - Steel safety break-out cable (for 1-circuit operation)
- 6 - Accumulator on manifold block
- 7 - Adjustment switch for 1-circuit/2-circuit operation
- 8 - Manual pump
- 9 - Brake line towards brake cylinder

Oil pressure can be released by means of the manual pump [8]. This pump can also be used to pump the pressurised oil in the brake cylinders towards the accumulator by hand.

If the handbrake of the tractor is pulled, the pressure in the supply line is cut off. Oil from the accumulator [6] will then be directed to the brakes, so that the parking brake of the tipping trailer is temporarily operated. This gives the operator time to pull the mechanical handbrake in a safe manner. Please refer to *Figure 5-17* position [1].

If control of the tipping trailer is lost while driving, the coupling will break away from the tractor and the pressure in the supply line will be cut off. A mechanical connection will then be made in the main coupling between the supply line and the return line as a result of this uncoupling. The oil

pressure in both lines will then be neutralised and the valves in the manifold block will be reset; in this way the accumulator pressure will be directed to the brakes of the tipping trailer.

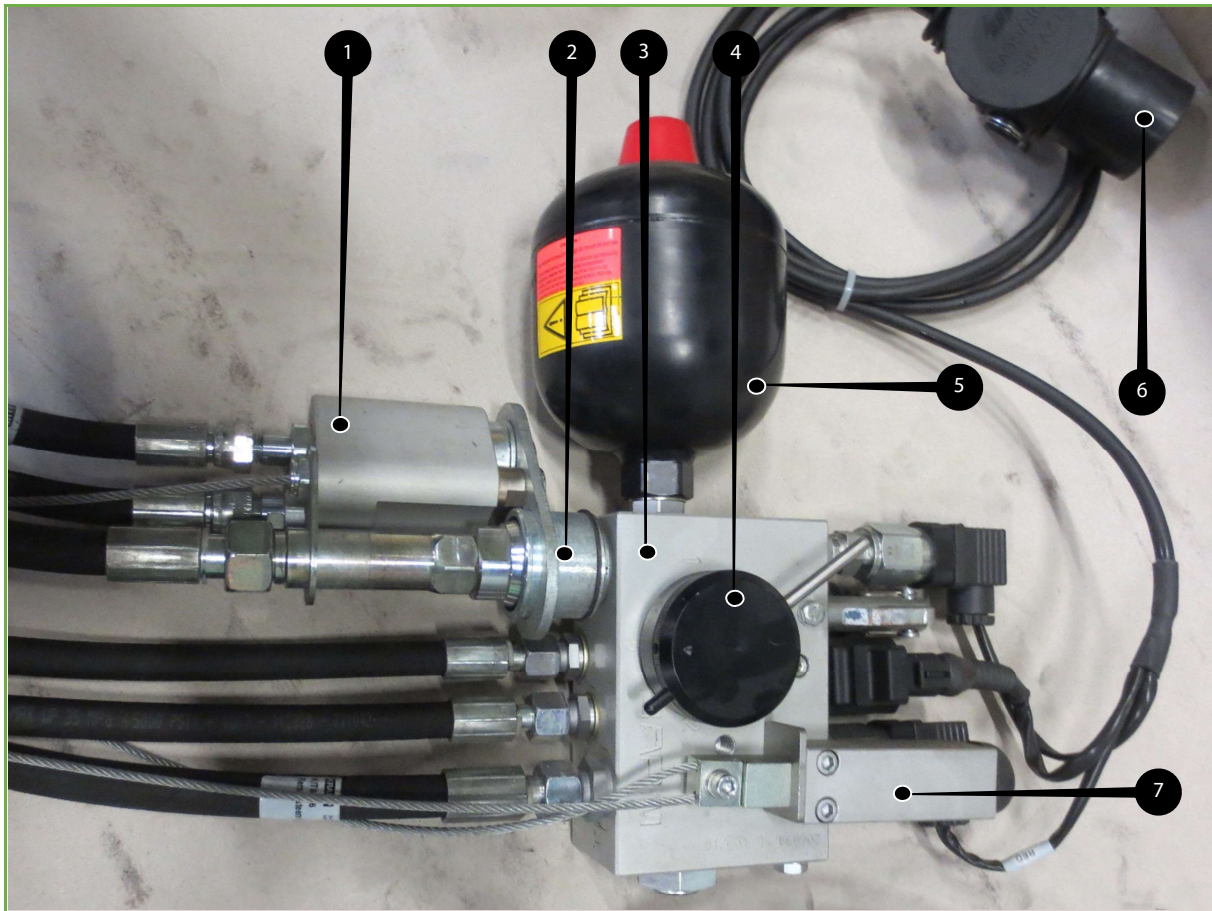

Figure 5-15: Hydraulic brake valve block (on drawbar)

- 1 - Double coupling
- 2 - Rest position (to keep the double coupling clean)
- 3 - Manifold block
- 4 - Adjustment switch for 1-circuit/2-circuit operation
- 5 - Accumulator
- 6 - ABS cable with plug (12V)
- 7 - Break-out safety mechanism (by means of steel cable; only for 1-circuit operation)

If the tipping trailer is coupled to a tractor with a single brake circuit, the adjustment button [4] must be set to position 2. The short pin of the adjustment button [4] will then be positioned in front of the small metal plate of the break-out safety mechanism. In the event of a break-out of the tipping trailer, the steel cable will activate the break-out safety mechanism. The adjustment button will be switched back to position 0 and oil from the accumulator will be directed to the brakes causing the tipping trailer's emergency brake to operate.

The ABS cable is not required for single-circuit operation.

The accumulator [1] will only fill when the brake pedal is applied. For this reason, the brake pedal should be applied several times before driving off each time the tractor/trailer is used in order to fill the accumulator. The indicator light on the dashboard will go out when sufficient pressure has built up in the accumulator. Make sure that the oil pressure of the tractor is sufficient to facilitate this operation.

- 1 - Accumulator
- 2 - Manifold valve block
- 3 - Adjustment button (1-circuit/2-circuit)
- 4 - Lever-operated pump (parking brake oil return to accumulator / circuit pressure relief)

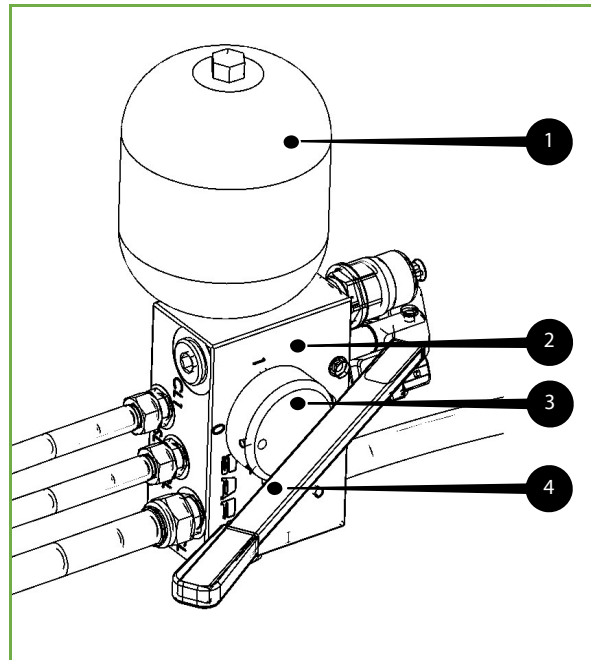

Figure 5-16: Hydraulic manifold valve block

If the tractor is not equipped with a 2-circuit system

1. Set the adjustment button [3] of the manifold block [2] to position 2.
2. Pump the brake fluid back into to the accumulator [1] using the lever-operated pump [4].

Upon connection of the trailer to a 2-circuit tractor, the adjustment button [3] will automatically reset to the zero position.

To operate the temporary parking brake of the tipping trailer

3. Set the adjustment button to zero by hand.

To reducing a build-up of oil pressure, if any, in the hoses to facilitate easy coupling

4. Set the adjustment button to zero.
5. Pump oil from the lines to the accumulator [1] using the lever-operated pump [4].



OBSERVATION:

Position 1 of the adjustment button [3] is not used.

The manifold block is monitored and operated electrically. It is not possible to disable the tipping trailer's parking brake when the adjustment button is in the zero position without an ABS (power supply) cable.

5.3.4 Manual pneumatic braking system (2-circuit)

The tipping trailer can be equipped with a pneumatically braked axle. This 2-circuit braking system is controlled by a hand-operated braking power control and meets EU requirements.

In addition to the normal braking function, the system includes a supply line that monitors the system. In the event of a break-out of the tipping trailer, the pressure in the supply line is cut off. The system then directs compressed air from the vessel to the brakes so that the tipping trailer is stopped by the emergency brake.

A hand-operated braking power control is available to adjust the braking power according to the cargo. Please refer to *Figure 5-18*. This 4-position hand-operated valve must be adjusted according to the degree of loading: empty, half-full or fully loaded.



OBSERVATION:

In accordance with EU legislation, the maximum permitted speed for trailers with a hand-operated braking power control is 30 km/h.



OBSERVATION:

A hand-operated braking power control may only be fitted to tipping trailers with fixed (not spring-loaded) axles.

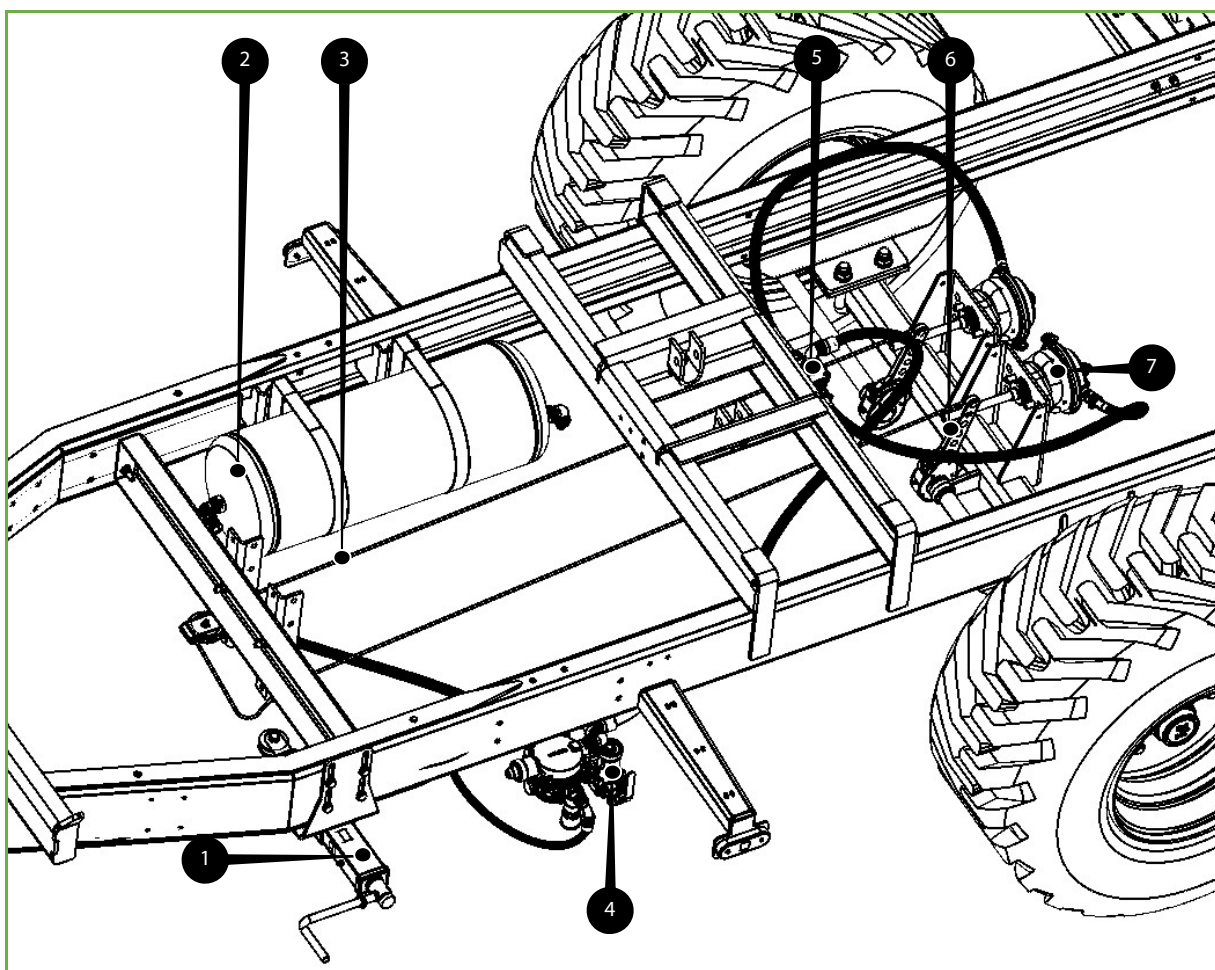

Figure 5-17: Pneumatic braking system (manual)

- 1 - Handbrake spindle
- 2 - Air vessel
- 3 - Handbrake cable
- 4 - Valve block with braking power control
- 5 - Quick release valve
- 6 - Brake lever (2 x)
- 7 - Pneumatic brake boosters

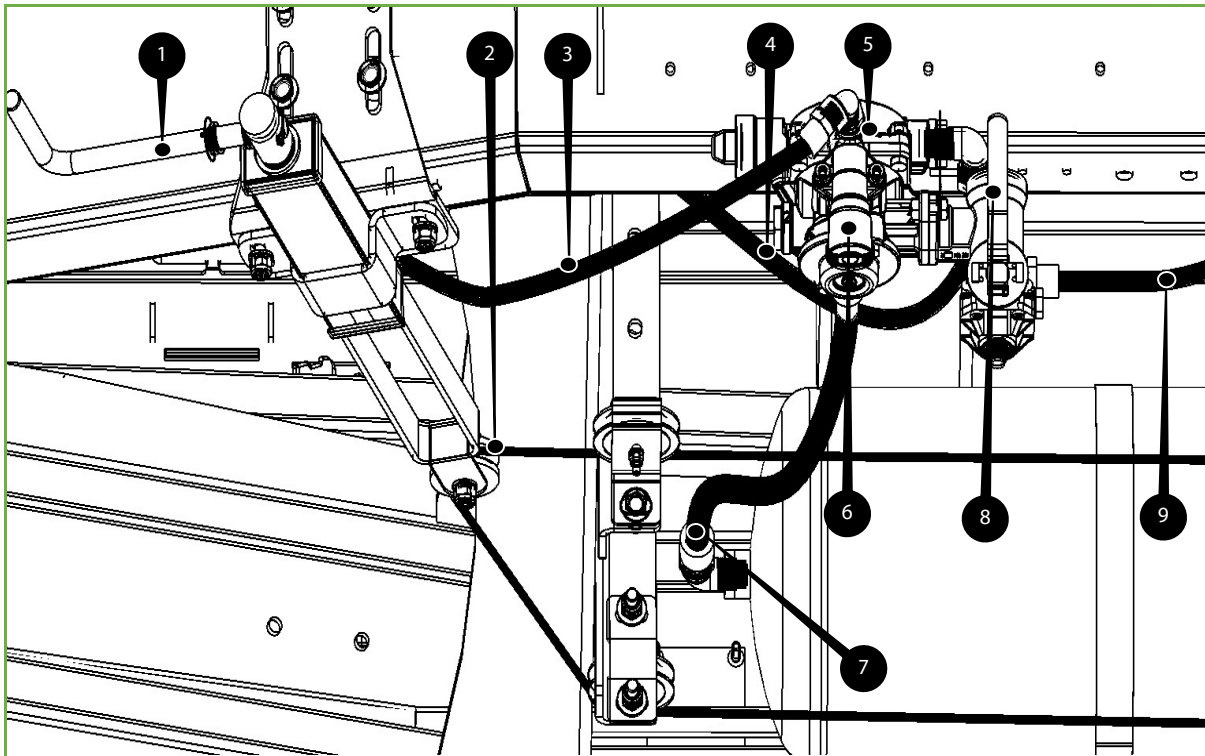

Figure 5-18: Pneumatic valve block with braking power control (manual)

- 1 - Spindle-type handbrake
- 2 - Brake cable
- 3 - Compressed air supply for tractor brakes
- 4 - Compressed air supply for tractor supply line
- 5 - Pressure control
- 6 - Discharge valve
- 7 - Air vessel connection
- 8 - Hand lever for manual load/braking adjustment
- 9 - Quick release connection to brake boosters

5.3.5 Automatic pneumatic braking system (2-circuit)

If the tipping trailer has a spring-loaded tandem carriage, it can be equipped with a pneumatically braked axle. This 2-circuit braking system is controlled by an automatic braking power control and meets EU requirements.

In addition to the normal braking function, the system includes a supply line that monitors the system to ensure that the pressure will be cut off if the tipping trailer should unexpectedly become uncoupled from the tractor. The system will then direct compressed air from the vessel to the brake boosters and the tipping trailer will be stopped by the emergency brake.

An automatic braking power control is available (for spring-loaded rear axles only) to adjust the braking power to the weight of the cargo. The valve operates according to the weight of the load as exerted on the spring-loaded axles.

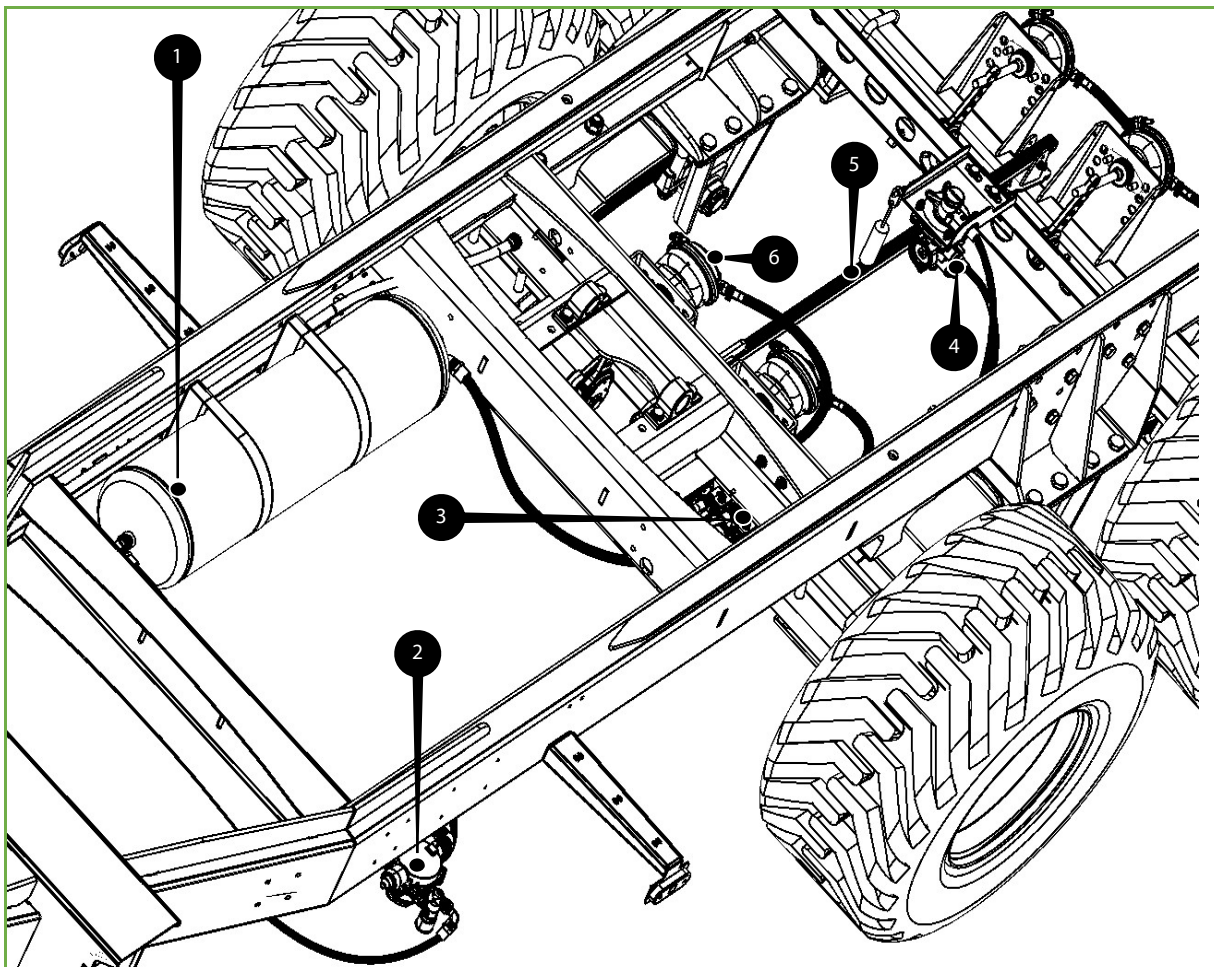

Figure 5-19: Pneumatic valve block with automatic braking power control

- 1 - Air vessel
- 2 - Brake valve
- 3 - Relay valve
- 4 - ALR valve
- 5 - ALR valve control arm
- 6 - Brake booster

5.4 Tipping the body

Before proceeding to tipping, the correct hinges must be selected and adjusted to the required direction of tipping. The operator should then release the locks on the appropriate side or rear board.

5.4.1 Selecting the direction of tipping

The tipping trailer pivots to the rear as standard. To that effect, the rear corners are equipped with pivot points [1] fitted with a locking pin [2] and a securing clip. Support arms [3] are sited at the front on which pivot points for the sideways tipping option are mounted.

Each of the pivot points is hinged in two directions, and locking pins are fitted on the side to which the tipping action is directed. For sideways tipping, the locking pins must be shifted to the side selected and secured, and the rear tailgate locking hooks of models Z030 and Z050 must be blocked. Please refer to *Figure 7-17*.

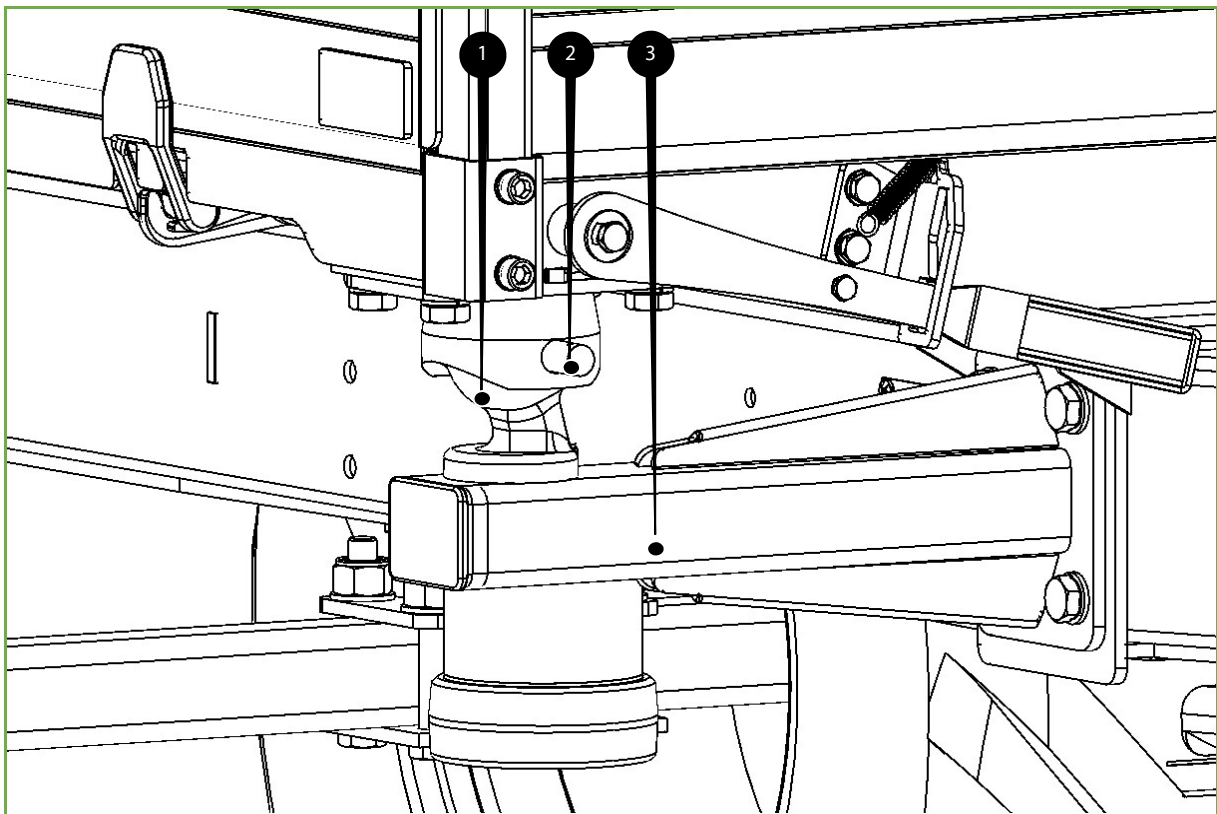

Figure 5-20: Locking of the tipping hinge

- 1 - Pivot ball
- 2 - Securing pin
- 3 - Support arm

5.4.2 Hydraulic tipping

Once the tipping direction has been selected and the appropriate side or rear board has been unlocked the body can be tilted. The tractor tipping valve, which controls the oil flow towards the tilt ram [3], is pressurised to this effect.

The tilt ram is fitted with a ball head [3]. The body has a ball pivot point [2].

- 1 - Ball head
- 2 - Ball pivot point on the body
- 3 - Telescopic tilt ram

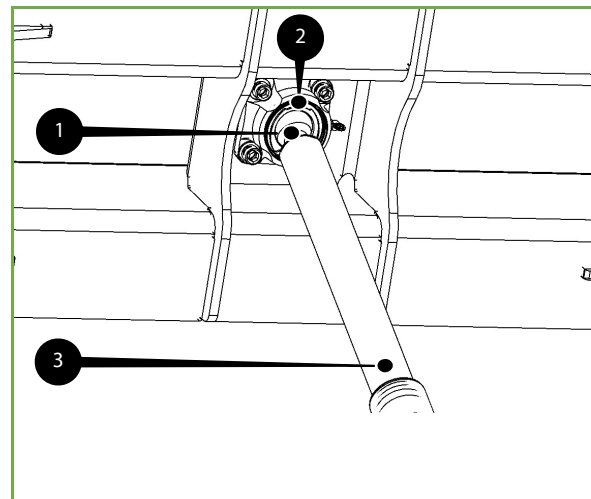

Figure 5-21: Hydraulic tilt ram

The telescopic tilt ram [1] is mounted on a cardanic suspension [3] in the chassis to enable movement in the various tipping directions.

During the tipping of the body, the ram [1] is checked by an end stop valve [2] (3-directional tipping only).

A hose rupture safety feature [4] ensures that the body cannot fall if the hydraulic hose fails.

- 1 - Hydraulic tilt ram
- 2 - End stop valve (3-directional tipping)
- 3 - Cardanic suspension of tilt ram
- 4 - Hose safety valve
- 5 - Hydraulic hose of end stop valve to tilt ram
- 6 - Hydraulic hose on tractor to end stop valve

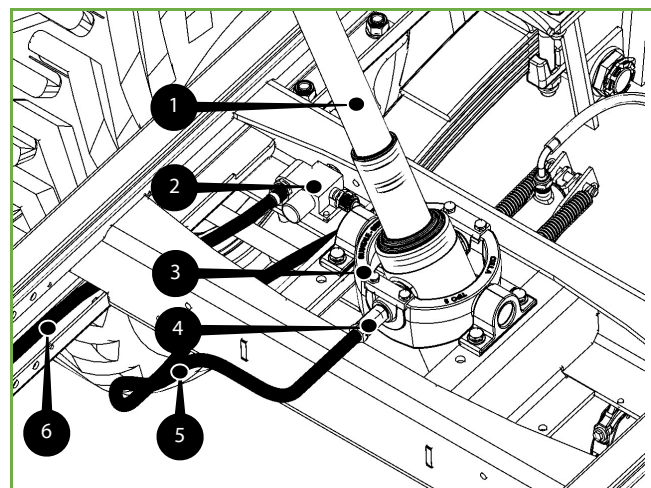

Figure 5-22: End stop valve

5.4.3 Mechanical safety bar

If it is required to enter the area underneath a raised body during maintenance, the mechanical safety bar [1] must be installed.

The mechanical safety bar can only be installed if the body is tipped backwards. With 3-side tipping selected, the tipping direction must be changed beforehand.

Lift the mechanical safety bar upwards and slowly lower the body onto the safety bar.

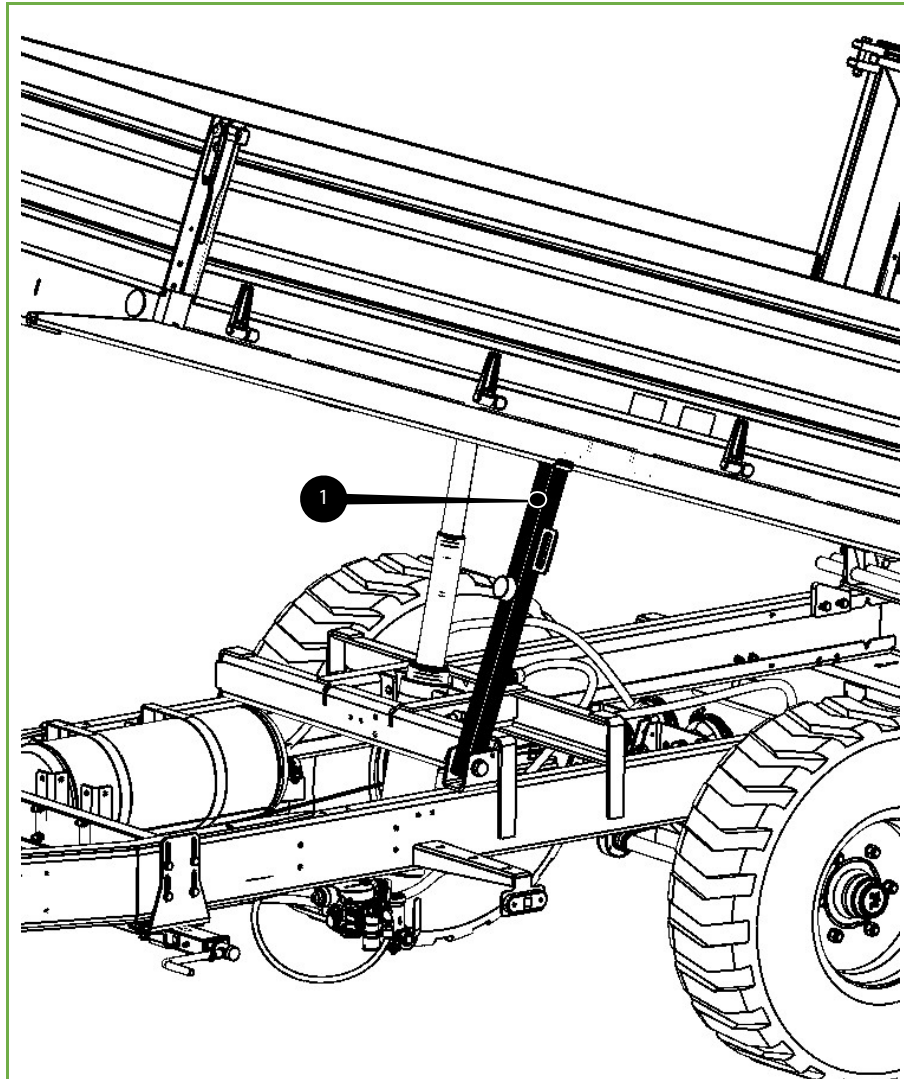

Figure 5-23: Mechanical safety bar

6. COMMISSIONING

Always read the entire Operating Manual before operating the tipping trailer for the first time.

OBSERVATION:



After the hydraulic hoses have been connected to the tractor, all hydraulic components must be filled with oil:

- apply the tractor brake vigorously three times to ensure that the accumulator [1] of the 2-circuit braking system is properly filled with oil;
- check the level and pressure of the oil in the tractor; it must be sufficient to fully extend the tilt ram.

6.1 Specific risks and dangers



DANGER of overloading:

Always observe the maximum permitted load of the tipping trailer!
Please refer to the serial plate on the trailer for the maximum loading capacity.



DANGER of break-out / breaking away:

Adhere to the maximum permitted statutory speed limit on public roads.



DANGER of toppling:

Ensure that the tipping trailer is on a level surface before proceeding to a tipping operation.



DANGER of pinching if oil pressure is cut off:

Keep clear of the tipper body when it is in the upright position.



WARNING:

Make sure that nobody is within the machine's unfolding zone when the locking hooks are being released.



ATTENTION:

Always ensure that the tipping trailer is regularly maintained.



ATTENTION:

Check that the drawbar eye is correctly secured by the locking pin after the tipping trailer has been coupled to the tractor.



ATTENTION:

Always ensure that all electric, hydraulic and pneumatic connections are fitted correctly and are functioning properly after the tipping trailer has been coupled to the tractor.

7. OPERATION

7.1 Preparatory tasks



OBSERVATION:

Before coupling, always check the tipping trailer for any defects or damage.

Be aware of the following points.

1. Check all nuts and bolts and tighten them if necessary.
2. Check that all fitting pins are secure.
3. Check that the locking hooks of the board are functioning properly.
4. Check the hydraulic circuit for leakage or other failures.
5. Check the pneumatic circuit for leakage or other failures.
6. Check the construction for possible defects.
7. Check that the tyre pressures are correct. Please refer to paragraph 8.1.

When you have assured yourself that the tipping trailer is free from any defect, you can begin the coupling procedure.

7.2 Adjustment of the tipping trailer

Various options are detailed in the following paragraphs. Follow the operational steps that apply to the relevant type of tipping trailer.

7.2.1 Adjustment of the drawbar

The drawbar must be fitted in the correct position to achieve the correct drawbar height.

1. Stand the tipping trailer on a firm and even surface.
2. Adjust the parking jack such that the body of the tipping trailer is in a horizontal position.
3. Measure the height of the coupling to the tractor. Please refer to paragraph 7.3.
4. Make sure that the drawbar eye is adjusted to the correct height.
5. Proceed as follows. Please refer to *Figure 7-1*.

1. Suspend the drawbar securely in a hoist.
2. Dismount the 4 bolts that connect the drawbar to the chassis.
3. Select the correct height, turning the drawbar if necessary. If the drawbar is turned, the coupling must be turned as well.
4. Mount the drawbar using the 4 bolts.

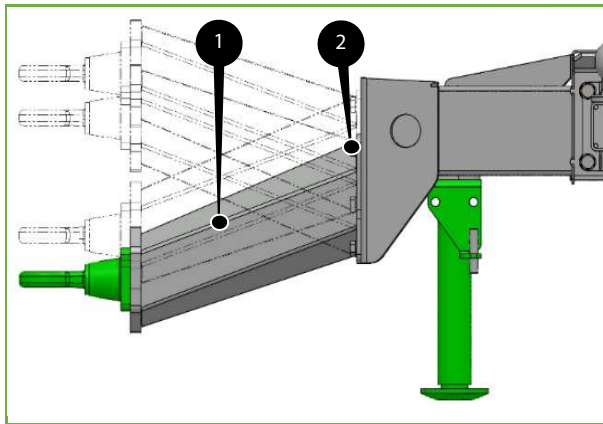

Figure 7-1: Adjustment of the drawbar

7.3 Coupling to the tractor



ATTENTION:

The tractor coupling and the drawbar eye of the tipping trailer cannot both be pivotable or non-pivotable.

One of the two must be pivotable and the other non-pivotable.

Carry out the following actions when coupling the tipping trailer to the tractor.

1. Position the tractor just in front of the tipping trailer.
2. Make sure that the relevant hydraulic spool valves of the tractor are not pressurised.
3. Switch off the tractor and remove the ignition key.
4. Couple the tipping trailer's drawbar eye [2] to the tractor.
5. Secure the locking pin in the correct manner.
6. Connect the following hydraulic hose(s) to the tractor:
 - a. tilt ram hose
 - b. hydraulic release (if available)
7. Connect the lighting and check lights for proper functioning.

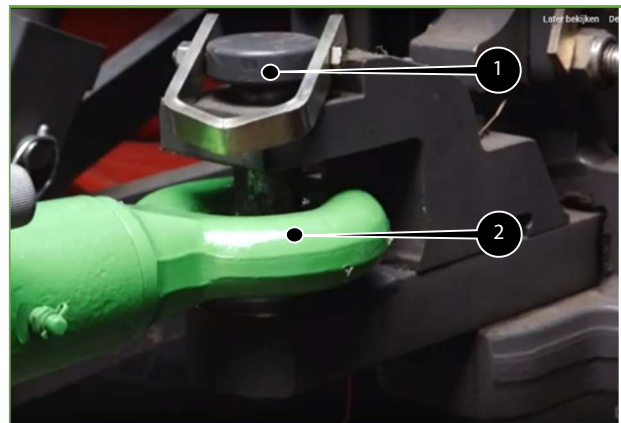

Figure 7-2: Coupling to tractor

1 - Locking pin of tractor coupling point

2 - Tipping trailer drawbar eye

Continue with one of the following steps.

7.3.1 For spindle-type parking jack:

1. Couple the tipping trailer to the tractor. Please refer to paragraph 7.3.
2. Using the spindle [1], raise the support wheel [6] to a point where the yoke [5] can be turned. Beware of the spring tension.
3. Lift the wheel using the bracket [4].
4. Tighten the screw spindle until the wheel is secured at the top.

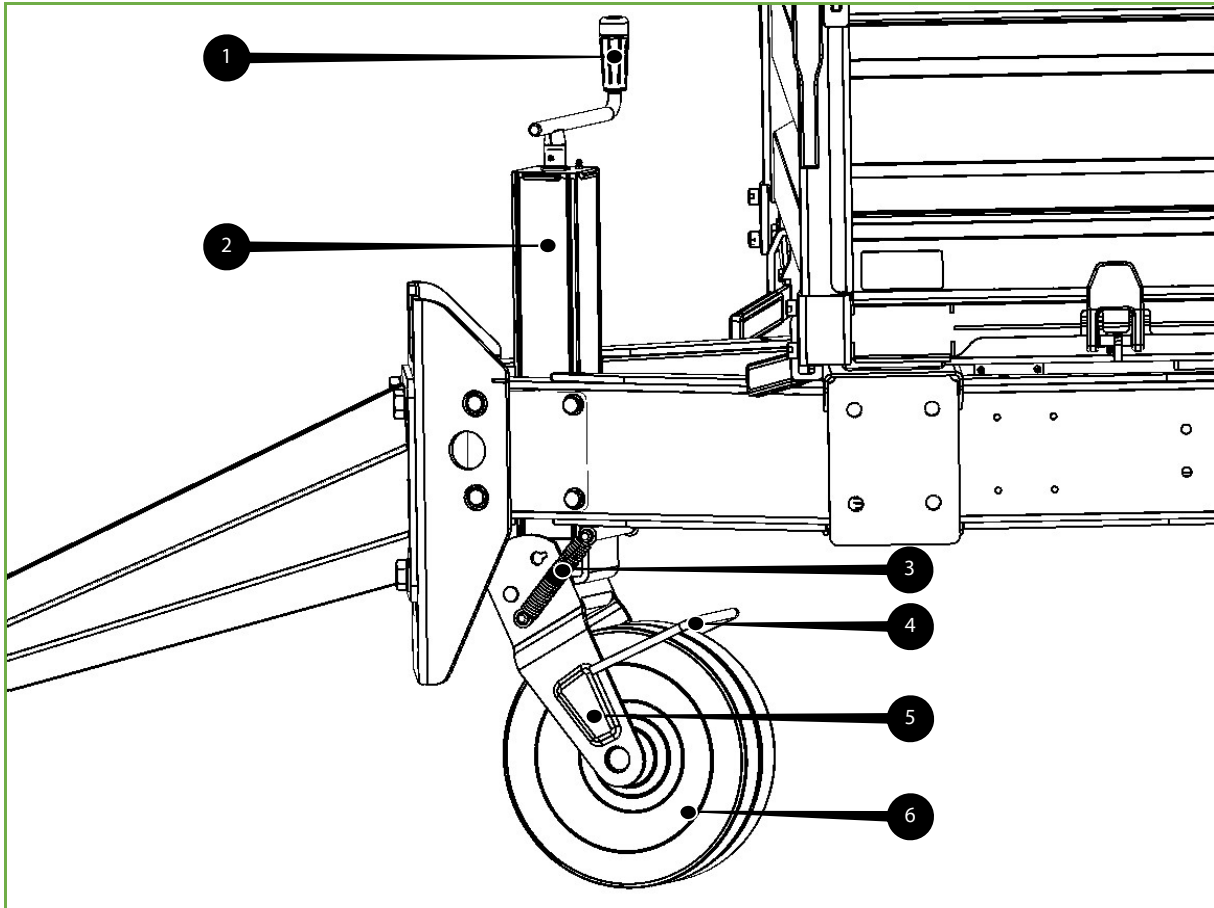

Figure 7-3: Spindle-type parking jack

- 1 - Spindle
- 2 - Spindle casing
- 3 - Spring
- 4 - Bracket
- 5 - Yoke
- 6 - Support wheel

7.3.2 For hydraulic parking jack:

1. Couple the tipping trailer to the tractor. Please refer to paragraph 7.3.
2. Connect the hydraulic hose [2] of the parking jack [5] to a single-acting hydraulic spool valve of the tractor.
3. Open the ball valve [1] of the hydraulic hose.
4. Release the hydraulic valve to retract the parking jack [5] completely.
5. Switch off the tractor and remove the ignition key.
6. Remove the locking pin [3] from the parking jack.
7. Lift the parking jack 90 degrees into a horizontal position.
8. Using the locking pin [3], secure the parking jack [4].

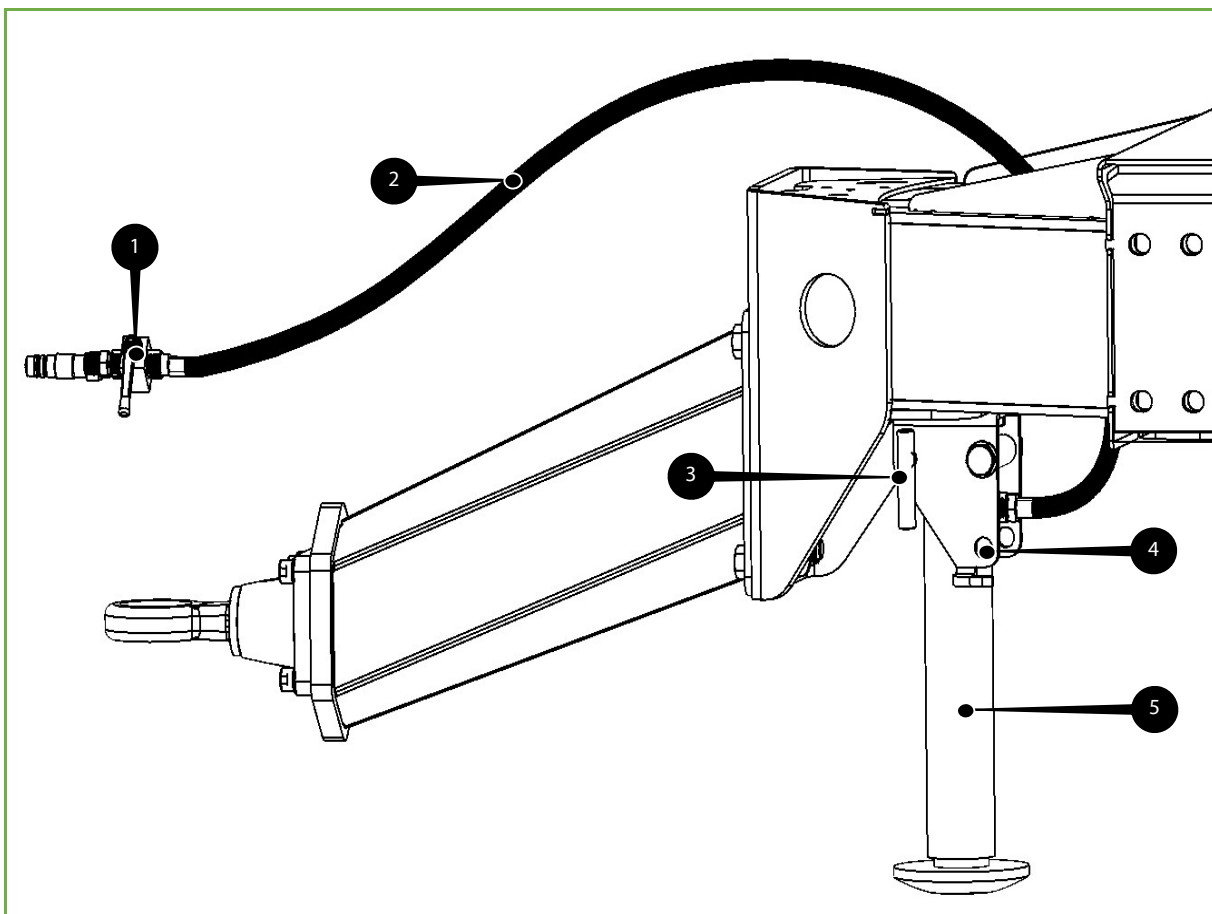

Figure 7-4: Hydraulic parking jack

- 1 - Ball valve
- 2 - Hydraulic hose for parking jack
- 3 - Locking pin
- 4 - 2nd locking pin location
- 5 - Hydraulic parking jack

7.3.3 For overrun brake:

1. Couple the tipping trailer to the tractor. Please refer to paragraph 7.3.
2. Tighten the brake lever slightly and press the button [1] to lift the catch.
3. Push the lever fully back to release the brakes.
4. Fix the break-out safety cord [2] of the handbrake to a solid point on the tractor.

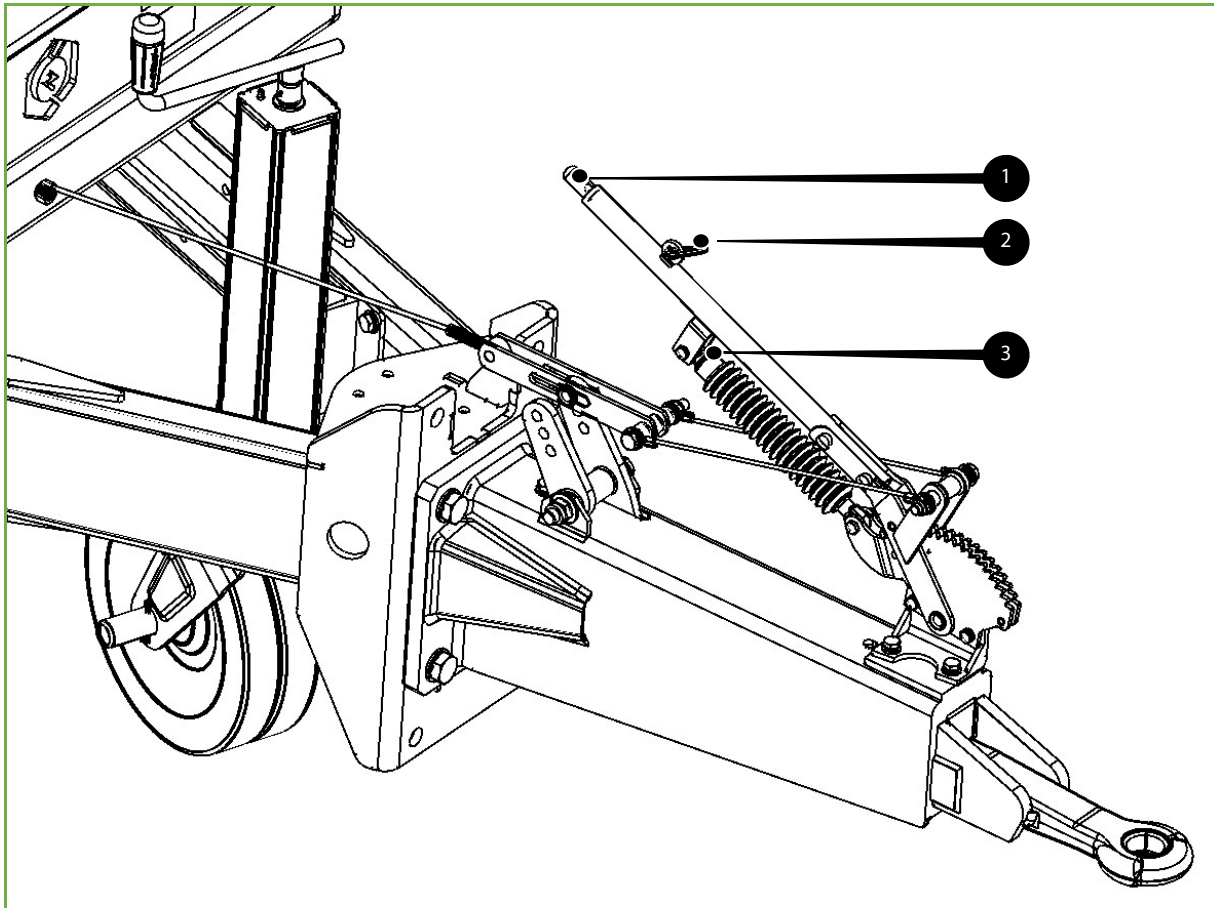

Figure 7-5: Overrun brake

- 1 - Overrun brake push-button
- 2 - Break-out safety cord attachment
- 3 - Handbrake with gas spring

7.3.4 For hydraulic brake (1-circuit system):

To use a 1-circuit tractor in combination with a 2-circuit tipping trailer please refer to paragraph 7.3.6.

1. Couple the tipping trailer to the tractor. Please refer to paragraph 7.3.
2. Connect the hydraulic brake line [1] to the tractor's brake coupling.

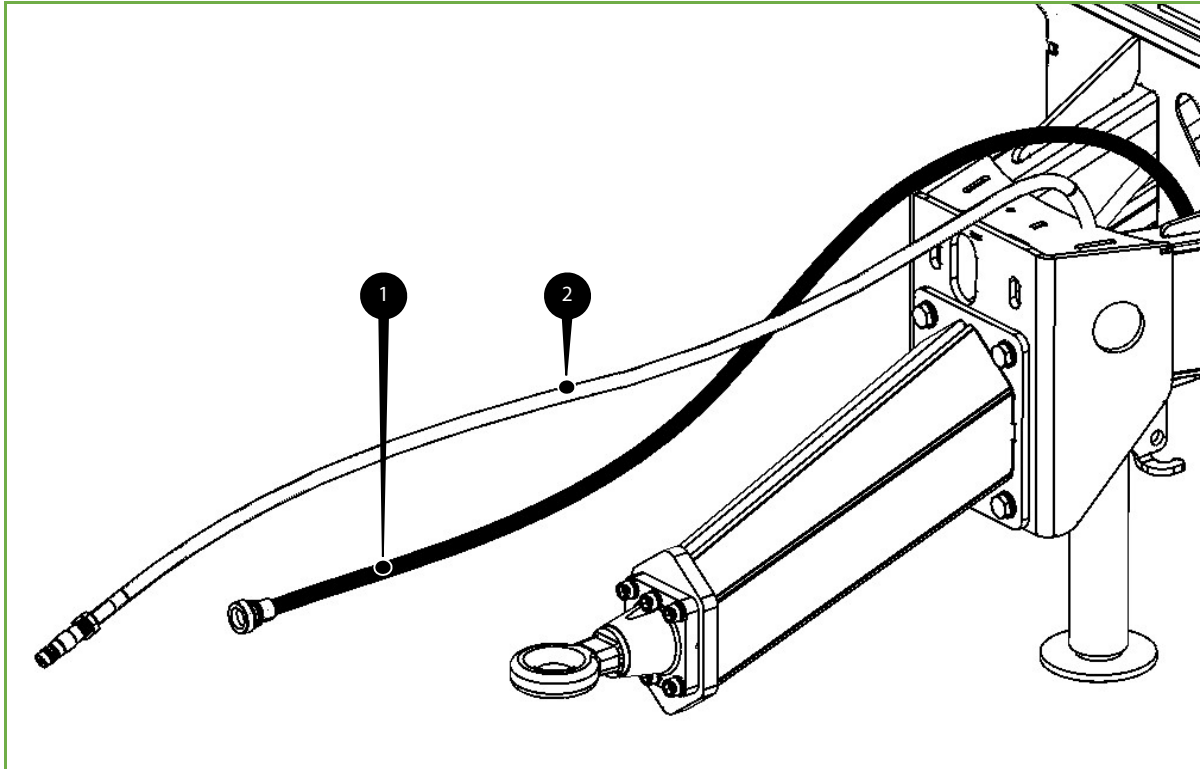

Figure 7-6: Hydraulic single circuit brake

- 1 - Hydraulic brake circuit
- 2 - Hydraulic hose for tipping

For break-out safety handbrake:

- a. Slightly tighten the handbrake lever [2] and then pull the lever entirely rearwards.
- b. Fit the break-out safety cord [1] of the handbrake to a solid point on the tractor.

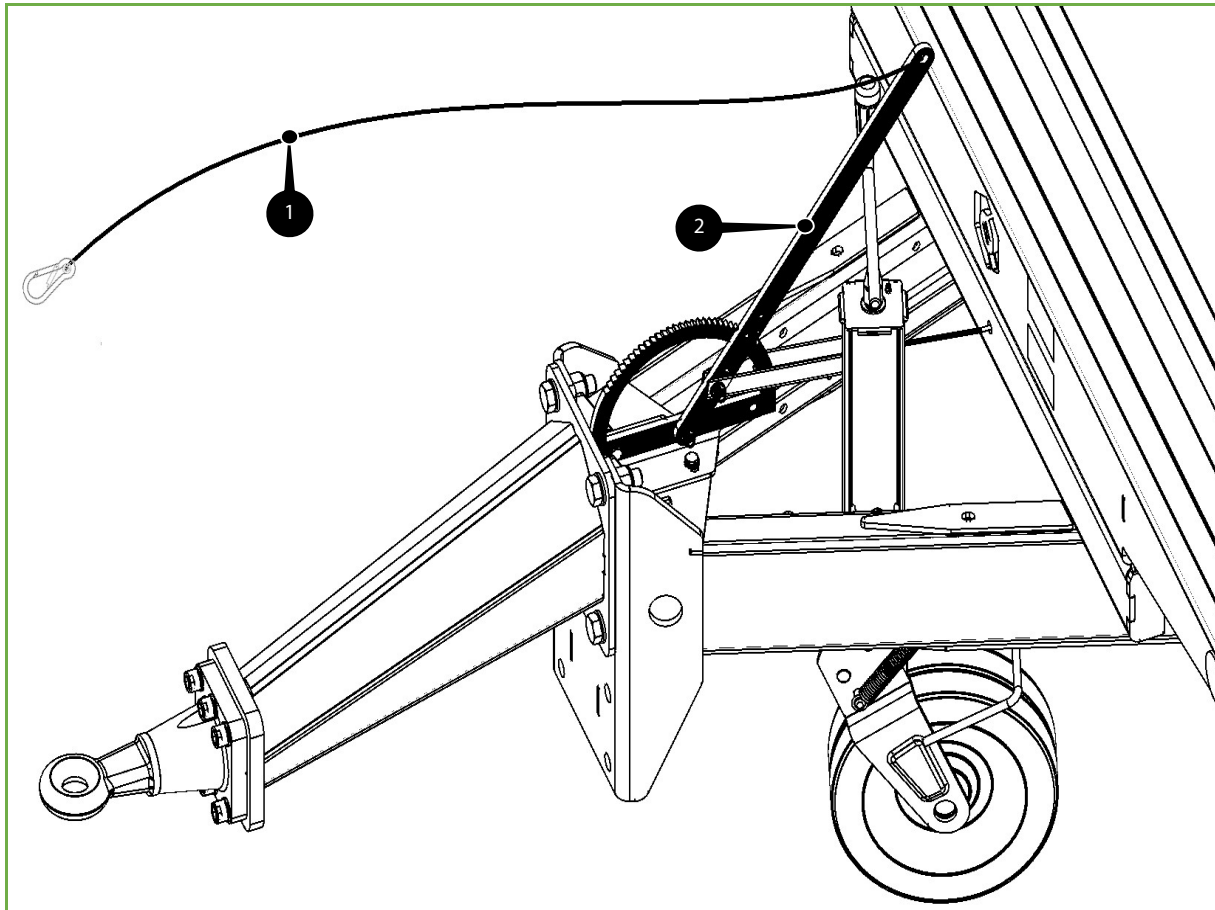

Figure 7-7: Break-out safety feature with handbrake

- 1 - Break-out safety cord
- 2 - Handbrake lever

For a spindle-type handbrake:

Turn the spindle [1] of the handbrake fully counter-clockwise until it will go no further. The brake cable [2] is then released and the brakes are inoperative.

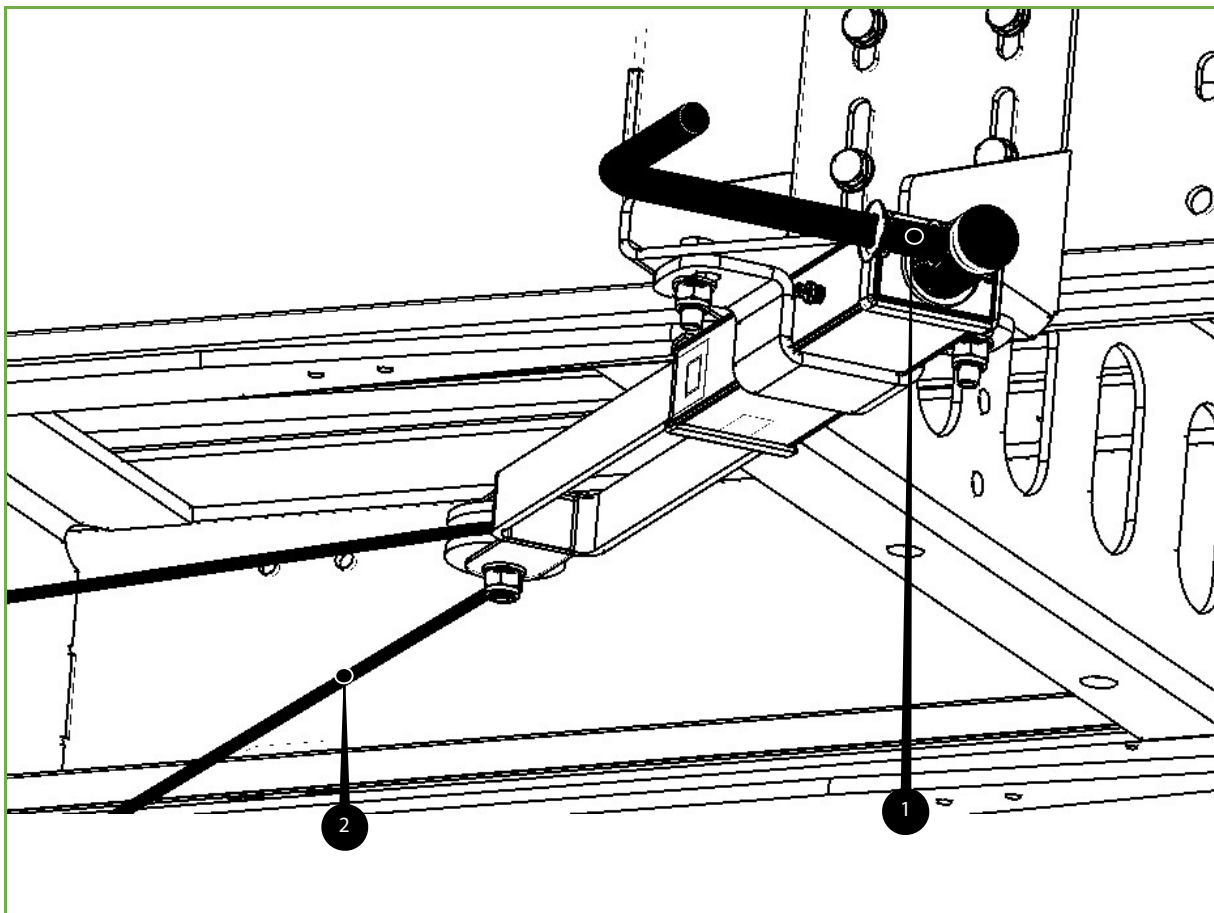

Figure 7-8: Spindle-type handbrake

- 1 - Spindle-type handbrake
- 2 - Brake cable

7.3.5 For hydraulic brake (2-circuit system):

To use a 1-circuit tractor in combination with a tipping trailer with a 2-circuit braking system please refer to paragraph 7.3.6.

1. Couple the tipping trailer to the tractor. Please refer to paragraph 7.3.
2. Insert the ABS plug into the tractor's ABS socket. Please refer to Figure 7-10.
3. Remove the double coupling from the rest position on the valve block. Please refer to Figure 7-12.
4. Connect the brake line [2] of the double coupling [1] to the tractor's brake coupling.
5. Connect the supply line [3] to the tractor's supply line coupling. The selection button on the manifold block will automatically set itself to the zero position. Please refer to Figure 7-13.
6. Turn the spindle [1] of the handbrake fully counter-clockwise until it can go no further. The brake cable [2] is then released and the brakes are inoperative. Please refer to Figure 7-8.

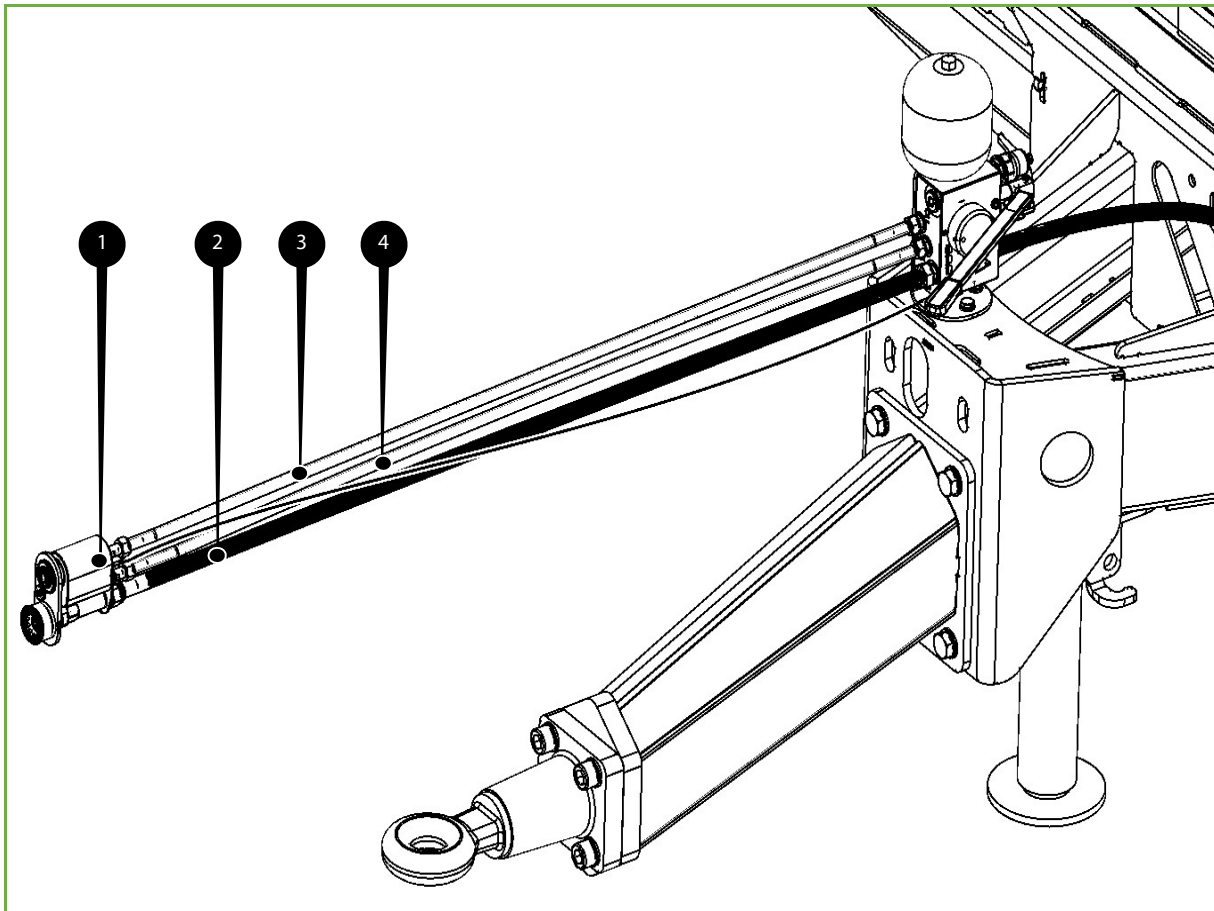

Figure 7-9: Double hydraulic brake coupling

- 1 - Double coupling with brake and control lines
- 2 - Main brake line
- 3 - Supply line
- 4 - Return line



Figure 7-10: ABS plug

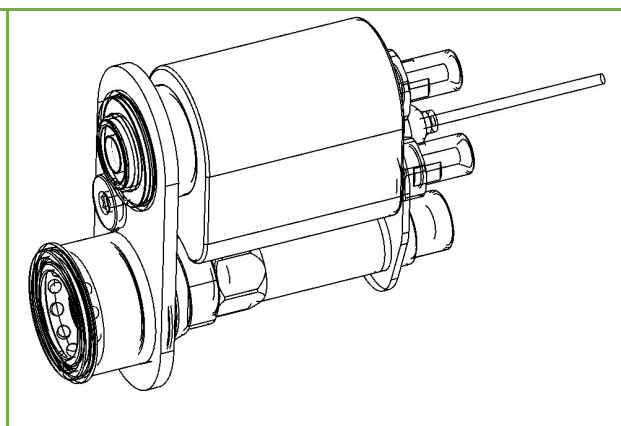

Figure 7-11: Double hydraulic connector

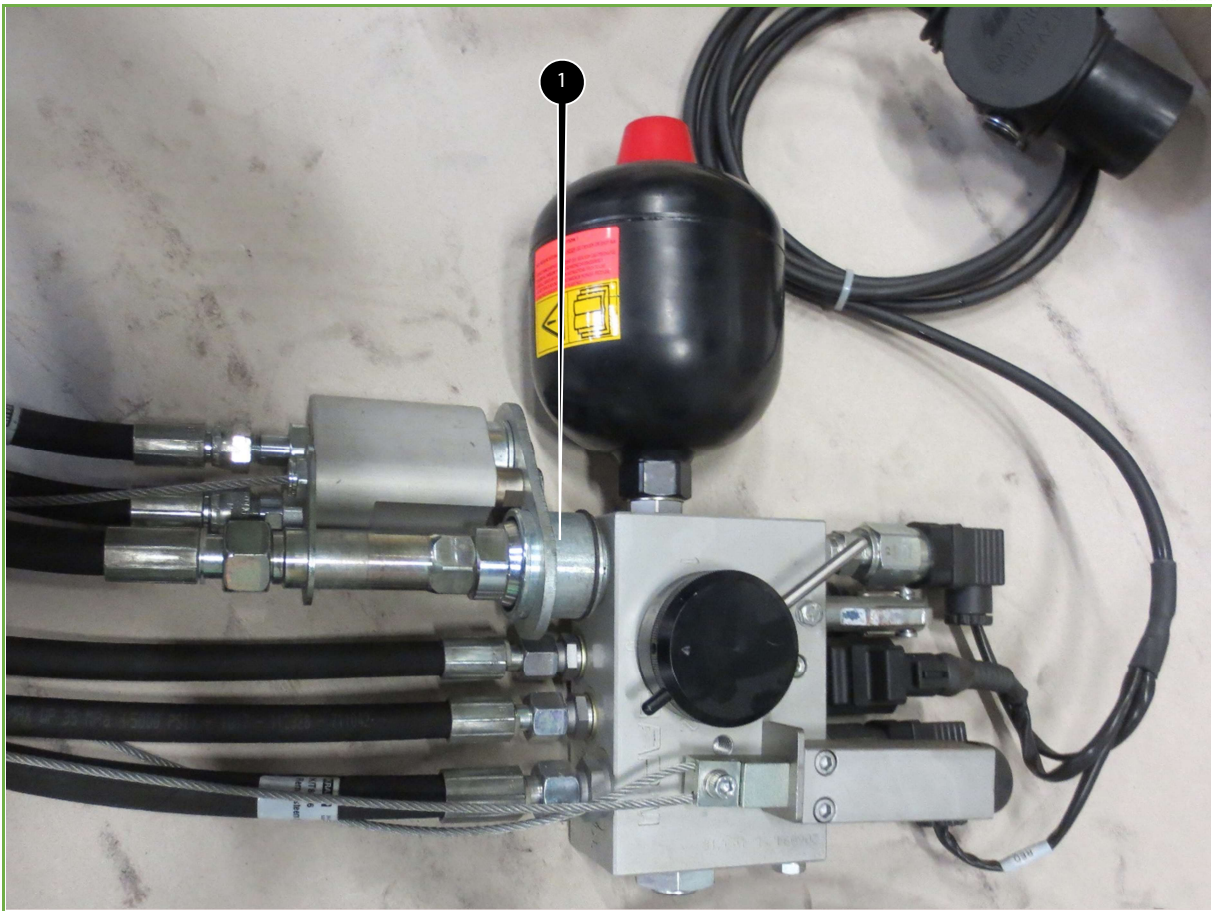

Figure 7-12: Rest position of hydraulic connector on manifold block

1 - Hydraulic connector

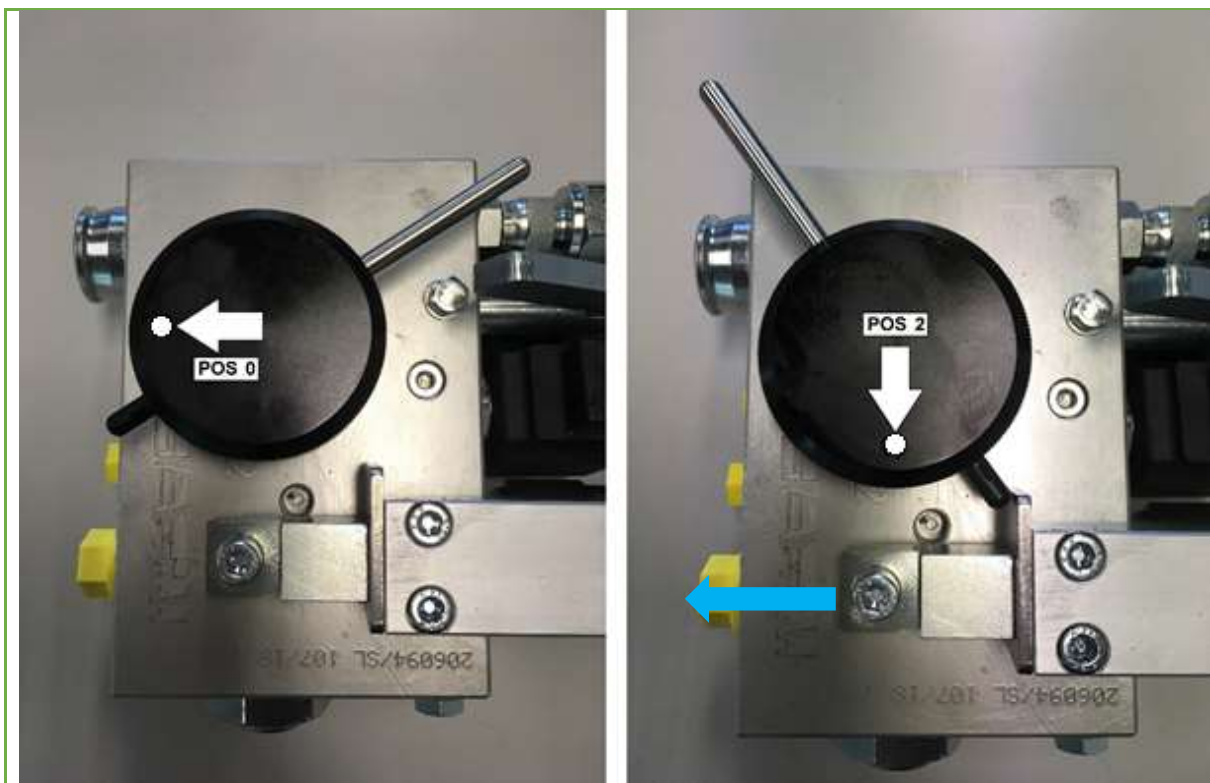

Figure 7-13: Positions of hydraulic brake valve with break-out device



OBSERVATION:

The selection switch is automatically set to the zero position. Please refer to *Figure 7-13*. (Position 2 is used for the break-out safety cord).

7.3.6 For hydraulic 2-circuit braking system and 1-circuit tractor:

1. Couple the tipping trailer to the tractor. Please refer to paragraph 7.3.
2. Connect the brake line [2] of the double coupling [1] to the tractor's brake coupling.
3. Set the selection switch of the hydraulic brake valve to position 2 for the use of a 1-circuit system.
4. Turn the spindle [1] of the handbrake fully counter-clockwise until it will go no further. The brake cable [2] is then released and the brakes are inoperative. Please refer to Figure 7-8.

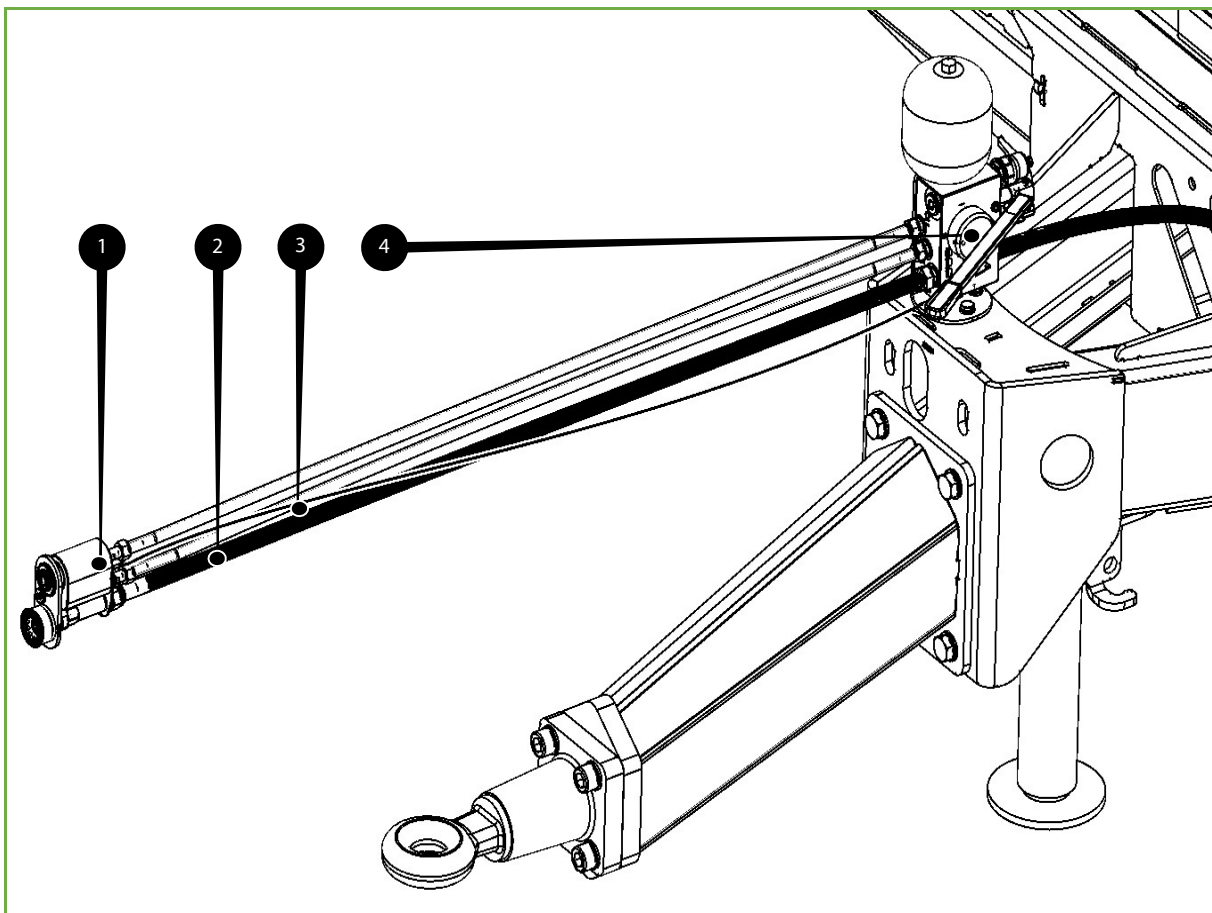

Figure 7-14: Hydraulic 2-circuit brake

- 1 - Double brake coupling with brake and control lines
- 2 - Main brake line
- 3 - Steel wire break-out safety feature
- 4 - Selection switch for 1-circuit or 2-circuit system

7.3.7 For pneumatic brake

1. Couple the tipping trailer to the tractor. Please refer to paragraph 7.3.
2. Drain the tipping trailer's air vessel.
3. Connect the yellow air supply line [2] to the tractor's yellow coupling.
4. Connect the red air supply line [1] to the tractor's red coupling.
5. Turn the spindle [1] of the handbrake fully counter-clockwise until it will turn no further. The brake cable [2] is then released and the brakes are inoperative. Please refer to Figure 7-8.
6. If applicable, adjust the 3-position brake-power control to the appropriate load.

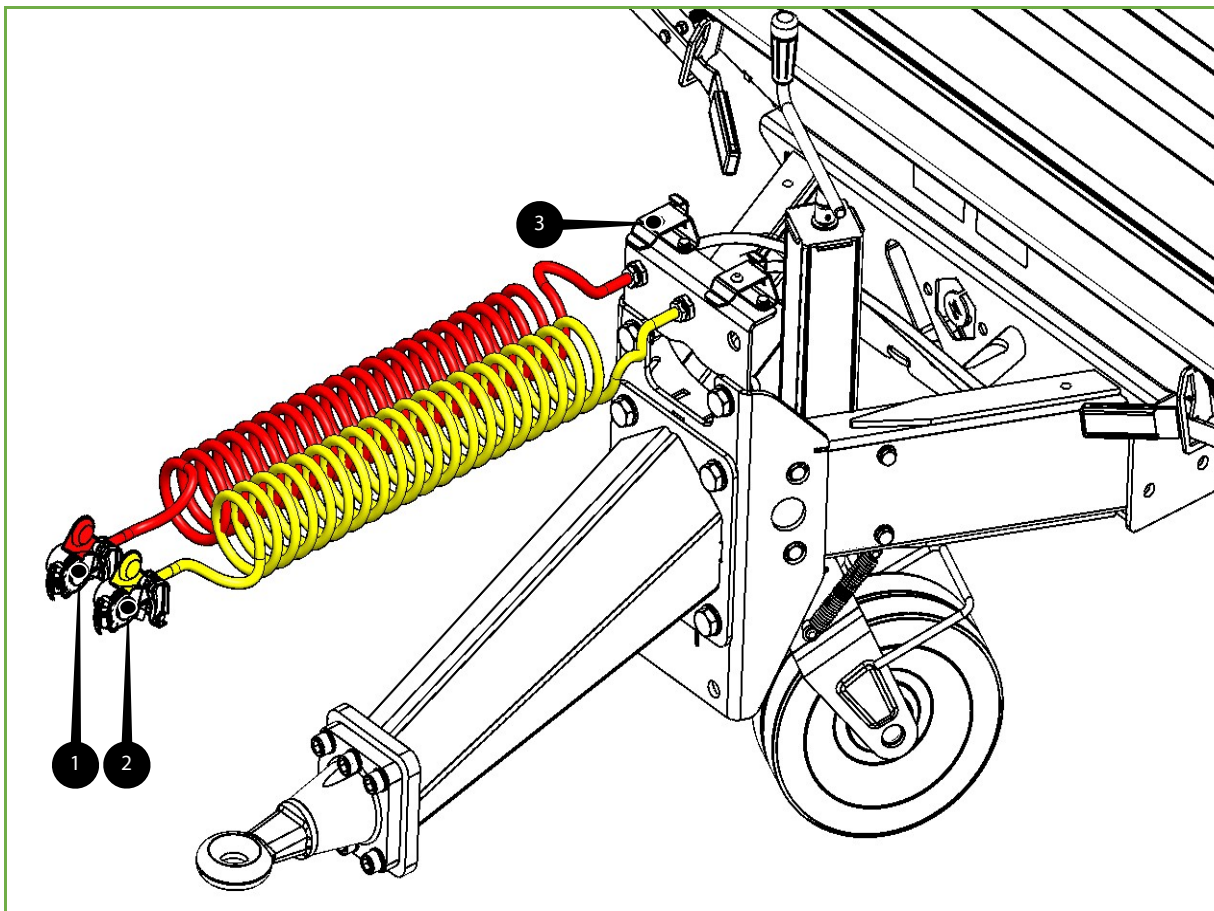

Figure 7-15: Pneumatic brake

- 1 - Supply line (red, to air vessel)
- 2 - Brake line (yellow)
- 3 - Dummy coupling of hose-support for brake air supply line

7.4 Uncoupling from the tractor

1. Position the tipping trailer on a firm and even surface.
2. Switch off the tractor and remove the ignition key.
3. Apply the handbrake of the tipping trailer.
4. If necessary, also block the wheels to prevent them from rolling.

7.4.1 For spindle-type parking jack:

1. Using the spindle, wind the parking jack down.
2. Drop the wheel.
3. Wind the parking jack down fully so that the tipping trailer's drawbar eye is released from the tractor coupling.
4. Uncouple the tipping trailer from the tractor. Please refer to paragraph 7.4.3.

7.4.2 For hydraulic parking jack:

1. Lift the parking jack slightly and remove the locking pin.
2. Let the parking jack hang straight down.
3. Using the locking pin, secure the parking jack.
4. Switch on the tractor.
5. Operate the hydraulic valve so that the parking jack descends until the eye of the drawbar is released from the tractor coupling.
6. Close the ball valve of the parking jack's hydraulic hose.
7. Uncouple the tipping trailer from the tractor. Please refer to paragraph 7.4.3.

7.4.3 Uncoupling:

1. Make sure that all hydraulic valves are in the neutral position.
2. Switch off the tractor and remove the ignition key.
3. Uncouple the following tractor connections (if applicable):
 - a. hydraulic brake lines
 - b. hydraulic hose(s)
 - c. air supply lines; connect these to the dummy connectors. Please refer to Figure 7-12.
 - d. break-out safety cord
 - e. plug for lighting
 - f. ABS plug
4. Uncouple the drawbar eye from the drawbar so that the tipping trailer is released from the tractor.
5. The tipping trailer is now completely uncoupled from the tractor.
6. Carefully drive the tractor away from the trailer.

7.5 Choice of tipping direction

7.5.1 Standard rearward tipping:

Position the locking pins of both ball pivots in the rear balls for rearward tipping. Please refer to paragraph 5.4.1.

For hydraulic unlocking

Adjust the hydraulic ball valves to the correct position. Please refer to *Figure 7-20*.

- Left valve [1] handle position irrelevant (tipping to the left/right).
- Right valve [2] handle position downwards.
- Operate the release valve on the tractor to unlock the rear tailgate before proceeding to tip.

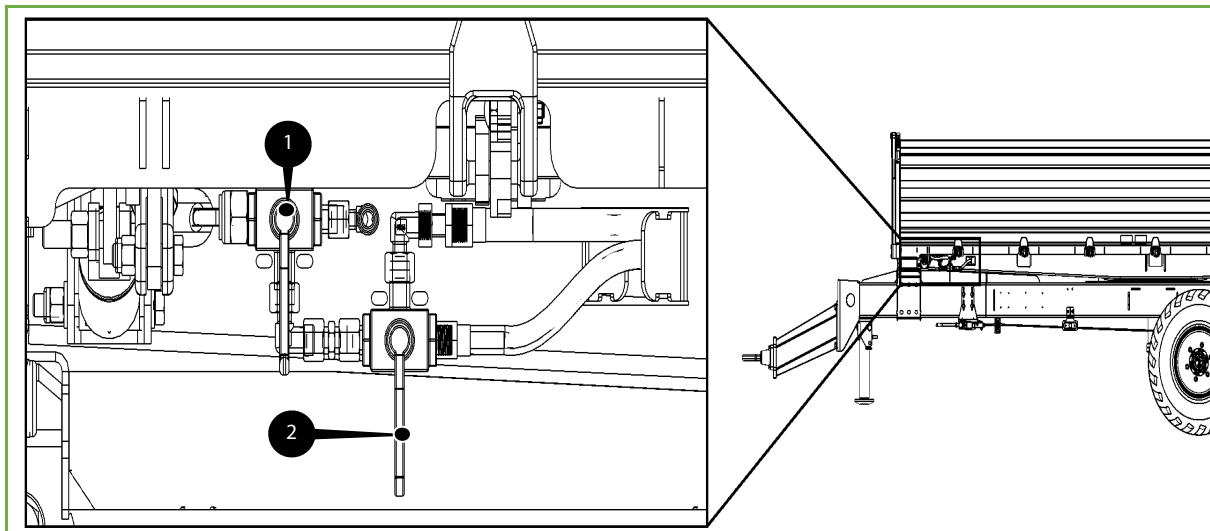

Figure 7-16: Valves for tipping direction

- 1 - Valve for left/right tipping direction, side board locking left/right
- 2 - Locking valve (rear board/ left side board / right side board)

To allow for pivoting of the rear tailgate as a whole (Z030 and Z050) upon unfolding doors:

- Keep the lock between the folding doors [2] secured. Please refer to Figure 7-17
- Unlock the securing pawls [1] of the rear tailgate. Please refer to paragraph 5.1.
- Operate the tipping valve. Please refer to paragraph 5.4.2.

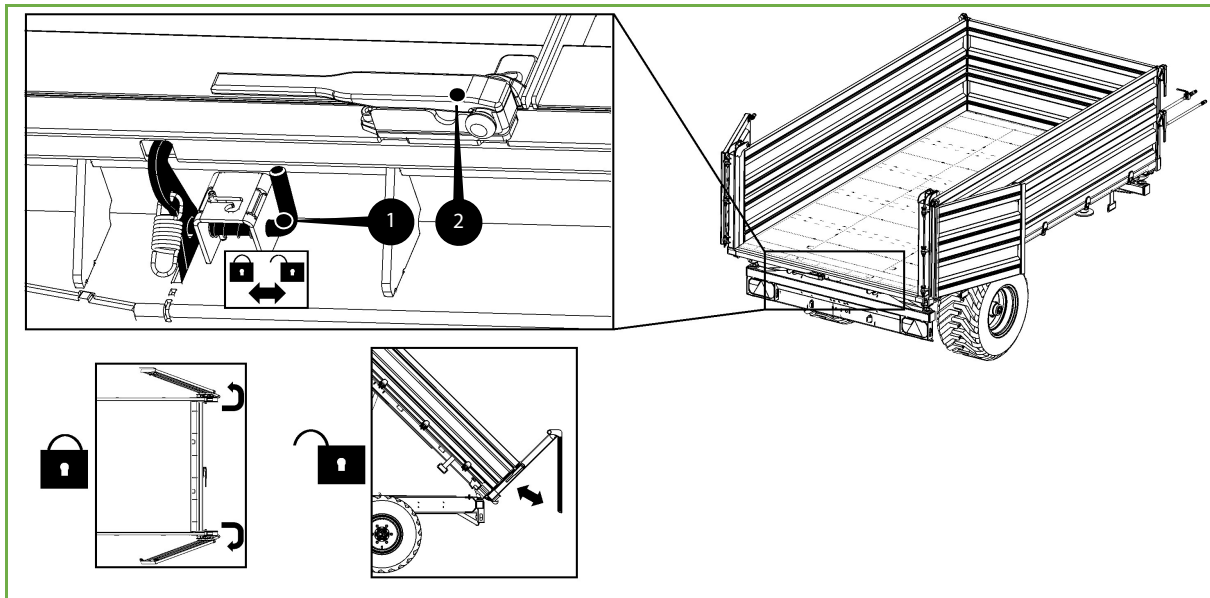

Figure 7-17: Securing the rear tailgate locking hooks - models Z030 and Z050

- 1 - Locking pawl
- 2 - Lowermost lock of folding doors

Use of rear tailgate folding doors (Z030 and Z050):

1. Leave the pawls [1] in the locking position to secure the door frame.
5. Open the two locks between the doors.
6. Open the doors.
7. Operate the tipping valve. Please refer to paragraph 5.4.2.

To allow for pivoting of the rear tailgate as a whole (Z045) with folding doors:

- Keep the lock between the folding doors [2] secured. Please refer to Figure 7-17
- Ensure that the locking pin [1] is positioned in the lowest hole. Please refer to Figure 7-18.
- Operate the tipping valve. Please refer to paragraph 5.4.2.

Upon the lifting of the body, the lock is automatically uncoupled when the locking rod [2] is released from the stop [3].

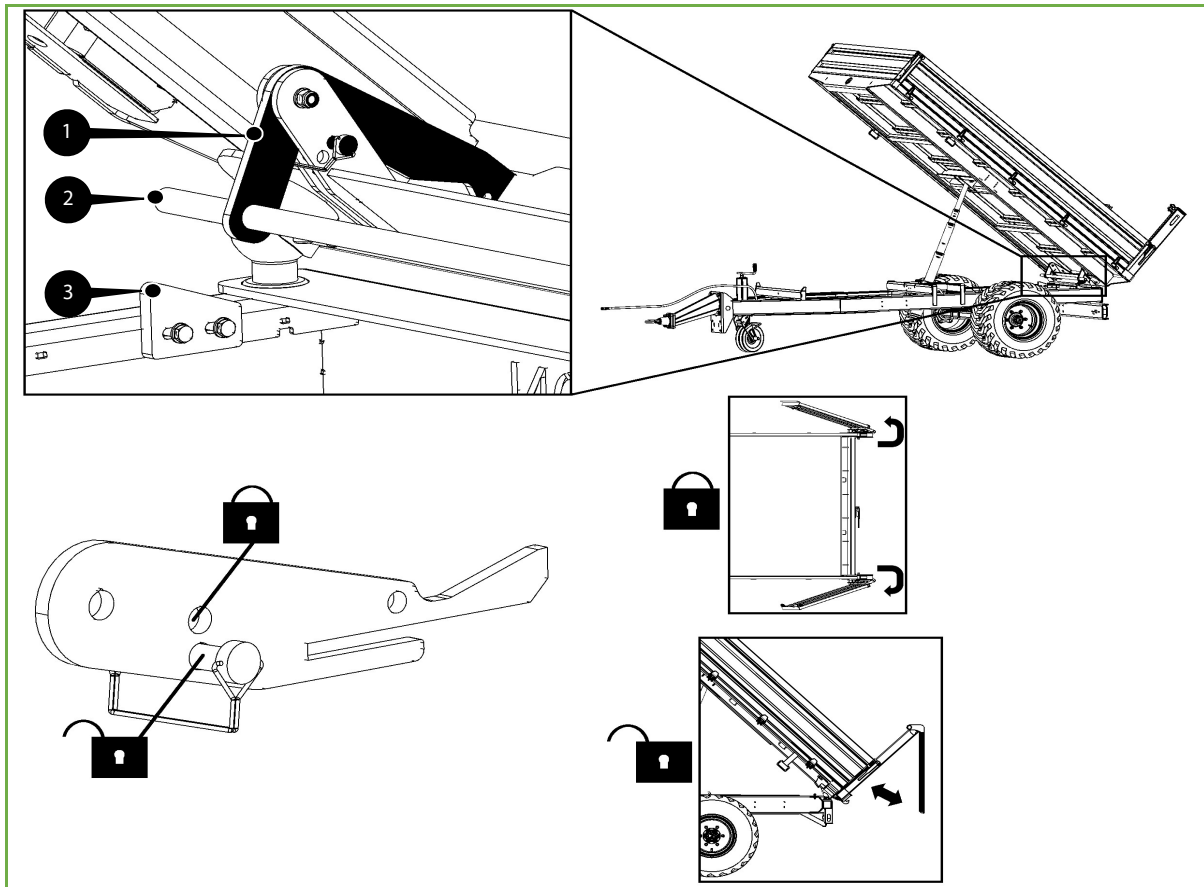

Figure 7-18: Securing the rear tailgate locking hooks - Z045

- 1 - Shiftable locking pin
- 2 - Locking rod
- 3 - Locking stop

Use of rear tailgate folding doors (Z045):

1. Place the locking pin [1] in the locked position to secure the door frame.
2. Open the two locks between the doors.
3. Open the doors.
4. Operate the tipping valve. Please refer to paragraph 5.4.2.

7.5.2 Sideways tipping:

Check that the locking pins of the ball pivots are both located on the same side of the balls.

Check that the rear tailgate locking hooks are secured. Please refer to *Figure 7-17*.

For mechanical unlocking:

- Push the handle [1] at the front of the body down slightly out of the hook and then push the handle upwards to unlock the side board.
- Re-position the handle in the lowest part of the hook to secure the side board after tipping.

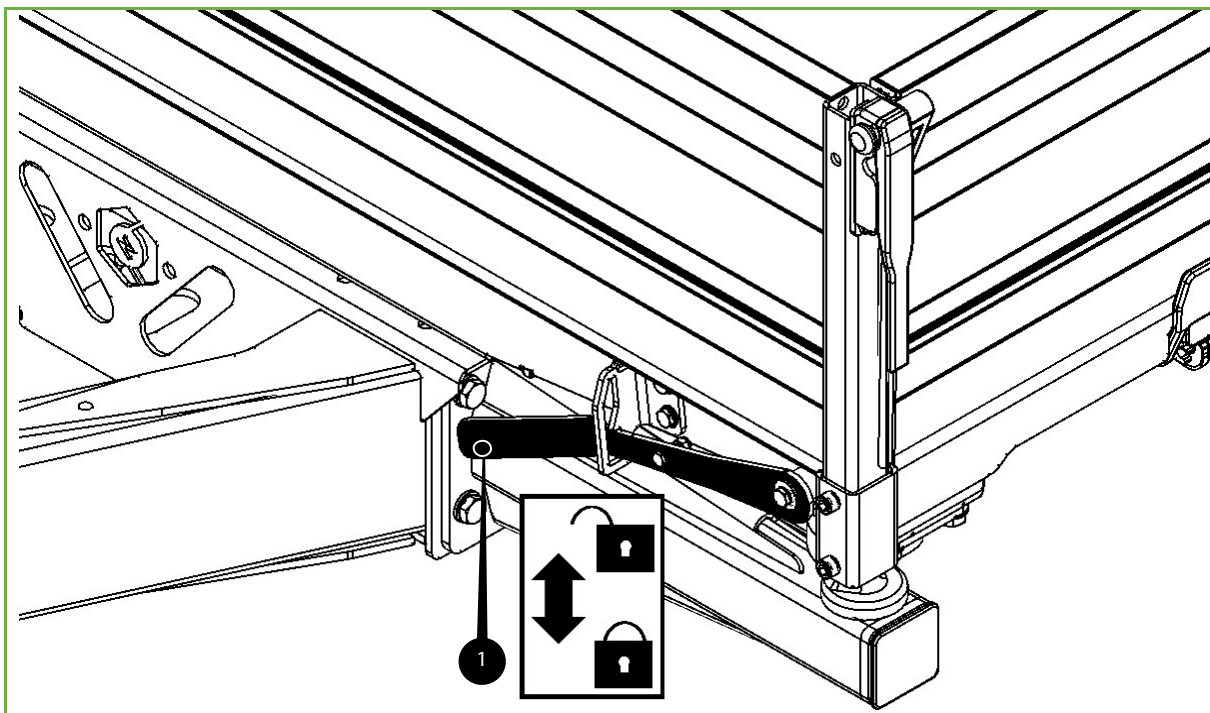

Figure 7-19: Securing the side board

1 - Side board locking handle

For hydraulic unlocking:

Check that the hydraulic ball valves are in the correct position. Please refer to *Figure 7-20*.

- L/H valve – handle position down
- R/H valve – handle position to the right
- Operate the unlocking valve on the tractor

Operate the tipping valve on the tractor. Please refer to paragraph 5.4.2.

7.5.3 Position of hydraulic valves during tipping operations

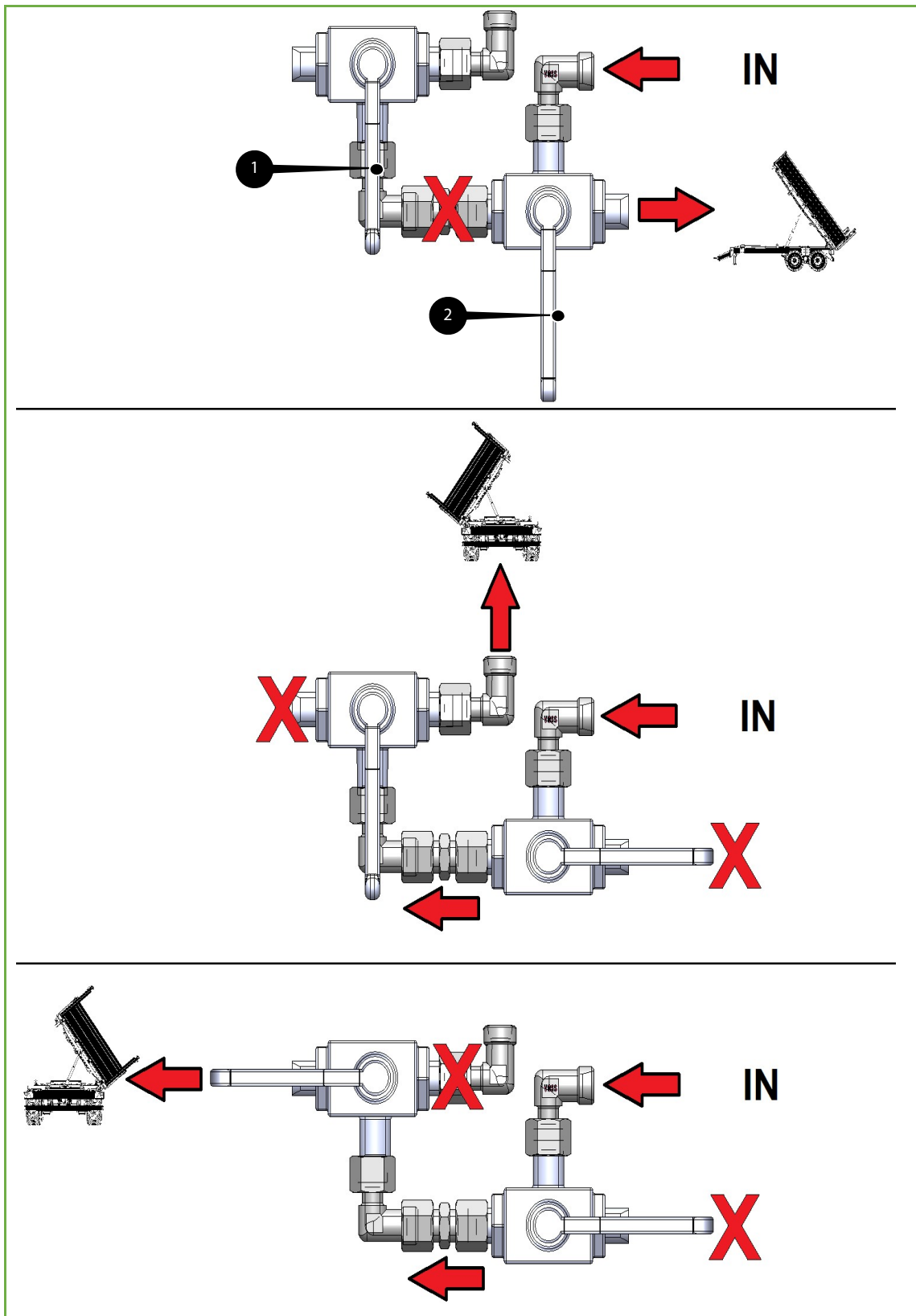

Figure 7-20: Position of hydraulic valves during tipping operations

- 1 - Valve for left/right tipping; side board locking left/right
- 2 - Locking valve (rear board/side board left/side board right)

7.6 During operations

7.6.1 Loading the body

Load the cargo in such a way that weight is evenly distributed across the body.

Unevenly distributed weight has negative consequences for the load on the drawbar and can make the tipping trailer unstable during the tipping operation.

If the cargo is small, it is advisable to load closer to the front of the body in order to exert a sufficient load on the trailer's drawbar.

Drop the load gently, in small quantities, into the body of the trailer. The sudden loading of larger volumes may cause damage to the trailer's drawbar, chassis or axles.



ATTENTION:

Do not exceed the maximum loading capacity (refer to serial plate).

- If applicable; adjust the hand-operated brake-power control to the correct size of load before driving off with the tipping trailer. Please refer to *Figure 2-22*.

7.6.2 Tipping the body

- Check that the tipping trailer is standing on a stable surface before starting to tip.
- Check that there is enough clearance above the body for the tipping operation.
- Check that there is sufficient hydraulic oil in the tractor to fully lift the tilt ram.
- Check that the correct tipping direction has been selected.



ATTENTION:

If the board has not been unlocked prior to the tipping operation, the trailer may topple and could even lift the tractor from the ground.



ATTENTION:

Ensure that there is nobody near the tipping trailer while the body is being tilted.

If fitted with a hydraulic locking system:

1. Operate the release valve on the tractor to unlock the rear tailgate.
2. Check whether the board has been unlocked for the tipping operation before the body is fully tilted.



ATTENTION:

If equipped with folding doors, it is important that the automatic locking system is not blocked by the manual locking if the standard rearward tipping function is used.

3. Operate the tilt valve on the tractor to tip the body.

4. Allow the load to slide gently out of the body. If applicable, drive forward slowly during the unloading process to make space.
5. Set the hydraulic valve in the neutral position to lower the body.
6. Check that the board is locked as the body descends.
For a hydraulic locking system, operate the hydraulic valve to lock the board.
7. If applicable, reset the manual brake-power control to 'Empty' before driving off with the trailer. Please refer to Figure 5-16:.

7.7 Hoisting of heavy components

The tipping trailer is equipped with side boards, a front wall and a rear tailgate, to which extensions or a gauze cover can be fitted.



OBSERVATION:

Most of these boards and extensions are too heavy to lift

Use a hoisting device when changing these components.



OBSERVATION:

Always wear safety shoes during hoisting and lifting operations.



OBSERVATION:

Always wear work gloves during hoisting and lifting operations.

Be aware of the following points during hoisting operations. Please refer to *Figure 7-21*.

1. Check the hoisting and lifting equipment for a valid inspection sticker.
2. Do not exceed the maximum hoisting load.
3. Ensure that the hoisting set up is stable.
4. Check that the hoisting belts [1] you use are undamaged.

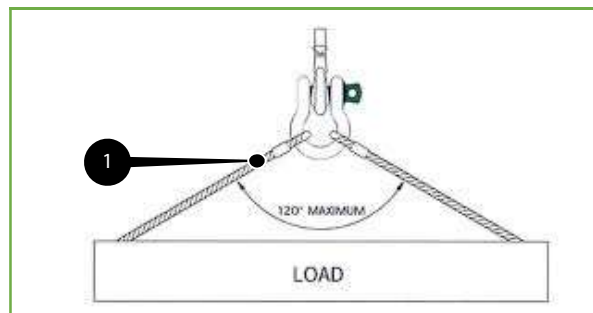

Figure 7-21: Hoisting

1 - Hoisting belt

7.7.1 Hoisting procedure for side boards

1. Place the slings around the side board well apart (hoisting angle between slings 120° as a maximum). If only one sling is used, it should be positioned in the middle.
2. Unfasten the upper locks. Please refer to Figure 5-6.
3. Position the slings.
4. Suspend the slings in the hoisting hook and tighten them.
5. Unfasten the lower lock by shifting the locking handle upwards. Please refer to Figure 5-7. (for the Z045 model, slide the side board from the hinges).
6. Position the board on blocks on a stable surface so that the hoisting belts can be removed.
7. Remove the hoisting belts [1].
8. To mount the board, follow the instructions in reverse order.

7.7.2 Fitting the extensions and gauze cover

OBSERVATION:



The extensions on the sides are not pivotable.

The lower board is used for the sideways tipping of the trailer.

(The use of extensions does not affect the rearward tipping operation.)

Additional means for mounting are factory-fitted at the rear of the side boards to enable the fitting of an extension.

A wall can be lowered into the U profiles to raise the height of the rear tailgate.

8. MAINTENANCE



OBSERVATION:

Please refer to the maintenance instructions below.
These are in force as and when applicable.

8.1 General maintenance



ATTENTION:

Always take the necessary safety precautions when carrying out maintenance and repairs.



ATTENTION:

Install the safety bar before entering the area underneath a raised body, Please refer to paragraph 5.4.3 Mechanical safety bar

Make sure that:

1. The tractor has been switched off (if coupled to the trailer).
2. The handbrake on the tractor and tipping trailer have been applied.
3. The tipping trailer is in a stable position (if not attached to the tractor).

The following maintenance tasks must be carried out after each operation.

1. Check tyre pressures. Please refer to Table 8-1.
2. Check all bolted connections and wheel nuts; tighten them if necessary.
3. Check the lights for function and visibility.
4. Check that the brakes (if fitted) are working.
5. Check the thickness of the brake linings. This must be 2mm as a minimum on all brake drums. An exception to this rule is the single axle of models Z080 and Z100, which must have brake linings with a thickness of 5mm as a minimum.
6. Check that the automatic rear tail gate lock is functioning correctly. The clamping force of the locking hooks can be adjusted by altering the tension on the springs.
7. Drain the air vessel of the pneumatic braking installation of any moisture.

8.2 Inspections

8.2.1 Handbrake

The handbrake must function properly; check this frequently.

8.2.2 Functioning of the braking device / break-out safety

1. Upon the coupling of the tipping trailer to the tractor the braking system of the trailer should go into the working position automatically.
2. If the tipping trailer is fitted with a break-out device this must be working correctly, which means that the tipping trailer's brake will operate automatically in the event of the trailer breaking-out.
3. Measure the pressure for the pneumatic brake-power control. Please refer to *Figure 2-22*.
4. Measure the pressure of the compressed air towards the pneumatic brake boosters (for each axle). Please refer to *Figure 5-17*.



OBSERVATION:

The adjustment of the pneumatic brake-power control should be performed by a qualified technician.

8.2.3 Adjustment of rear tailgate locking hooks

When the loading board is in a flat position, the automatic locking hooks must secure the rear tailgate. The position of the locking hook can be adjusted by means of an adjustment bolt. Please refer to *Figure 5-2*.

1. Check that the body is in the lowest position.
2. Lock the rear tailgate.
3. Loosen the locking nut of the adjustment bolt.
4. Tighten the bolt until the locking hook is positioned against the rear tailgate and cannot be lifted any further.
5. Tighten the locking nut.
6. Proceed in the same way for the other locking hook.

8.2.4 Wheel replacement



ATTENTION:

Always position the lifting jack on a firm and even surface.

Be sure to use a jack with a sufficient lifting capacity. The use of an inappropriate jack can be dangerous!



OBSERVATION:

Always wear safety shoes when changing a wheel.



OBSERVATION:

Always use work gloves when changing a wheel.

1. Always apply the tipping trailer's handbrake when uncoupling the vehicle. If necessary, also block the wheels to prevent rolling.
2. Use a jack with a sufficient lifting capacity. With the wheel on the ground, place the jack directly underneath the wheel axle as close as possible to the wheel.
3. Partially loosen the wheel nuts, but do not yet remove them from the bolts.
4. Using the jack, lift the wheel from the ground.
5. Remove the nuts.
6. Carefully remove the wheel without damaging the bolts.
7. If a spare wheel is not immediately available, use blocks to support the axle to take the weight off the lifting jack.
8. Have the wheel (or tyre) repaired professionally, or use a new wheel.
9. Fit the repaired wheel back onto the hub, once more taking care not to damage the bolts.
10. Replace the wheel nuts and tighten them by hand; make sure that the rim is properly connected to the hub.
11. Carefully lower the wheel using the lifting jack.
12. Set the torque wrench at 330 Nm (bolt M18 class 10.9) or 450 Nm (bolt M22 class 10.9).
13. Using the torque wrench, tighten the wheel nuts cross-wise until all have been tightened at the correct torque.
14. Check the tyre pressure. Please refer to Table 8-1.
15. Re-tighten the bolts again after the first 8 hours of operation.

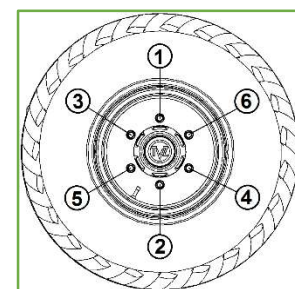

ATTENTION:

Risk of explosion!

Never pump the tyres up to a higher pressure than specified.

Use the correct tyres for the tipping trailer, paying particular attention to the correct carrying capacity. Please refer to *Table 8-1*.

Table 8-1: Overview of tyres

Tyre size	Make	Profile	PR	Load/speed index	Carrying capacity	Offset size	Air pressure (kPa/bar)	Applicability to tipping trailer type					
10.0/75-15.3 ET0 14PR 130 A8	BKT	AW 909	14	130 A8	1900	ET0	710 / 7.1	Z030*					
11.5/80-15.3 ET0 10PR 131 A8	BKT	AW 909	10	131 A8	1950	ET0	460 / 4.6	Z030					
11.5/80-15.3 ET0 14PR 139 A8	BKT	AW 909	14	139 A8	2430	ET0	650 / 6.5		Z045*		Z080 (1)		
11.5/80-15.3 ET0 18PR 145 A8	BKT	AW 702	18	145 A8	2900	ET0	710 / 7.1			Z050*			Z100 (1)
15.0/55-17 ET+40 10PR 134 A8	BKT	AW 909	10	134 A8	2120	ET+40	360 / 3.6	Z030					
15.0/55-17 ET0 14PR 141 A8	BKT	AW 909	14	141 A8	2575	ET0	490 / 4.9				Z080*(1)	Z100*(1)	
15.0/55-17 ET+40 14PR 141 A8	BKT	AW 909	14	141 A8	2575	ET+40	490 / 4.9		Z045	Z050			
19.0/45-17 ET-70 10PR 138 A8	BKT	AW 708	10	138 A8	2360	ET-70	300 / 3.0				Z080 (1)		
19.0/45-17 ET-70 14PR 144 A8	BKT	AW 708	14	144 A8	2800	ET-70	390 / 3.9						Z100 (1)
19.0/45-17 ET+35 14PR 144 A8	BKT	AW 708	14	144 A8	2800	ET+35	390 / 3.9		Z045	Z050			
500/50-17 ET-100 10PR 140 A8	BKT	AW 708	10	140 A8	2500	ET-100	270 / 2.7				Z080 (1)		
500/50-17 ET0 10PR 140 A8	BKT	AW 708	10	140 A8	2500	ET0	270 / 2.7		Z045				
500/50-17 ET+70 10PR 140 A8	BKT	AW 708	10	140 A8	2500	ET+70	270 / 2.7			Z050			
500/50-17 ET-100 14PR 152 A8	BKT	AW 708	10	152 A8	3550	ET-100	380 / 3.8						Z100 (1)
500/50-22.5 ET-50 16PR 158 A8	BKT	Flotation 648	16	158 A8	4250	ET-50	300 / 3.0				Z080 (2)		
550/45-22.5 ET-50 16PR 158 A8	BKT	Flotation 648	16	158 A8	4375	ET-50	280 / 2.8				Z080 (2)		
550/45-22.5 ET-50 20PR 166 A8	BKT	Flotation 648	20	166 A8	5300	ET-50	400 / 4.0						Z100 (2)
									* Standard tyre		1) Configuration with tandem axle 2) Configuration with single axle		

8.3 Periodic maintenance



ATTENTION:

Always take the necessary safety precautions when carrying out maintenance and repairs.



ATTENTION:

Install the safety bar before entering the area underneath a raised body, Please refer to paragraph 5.4.3 Mechanical safety bar

(If applicable)

8.3.1 Lubrication points

- 1 - Tipping pivots (2 or 4 off)
- 2 - Carriage (tandem)
- 3 - Drawbar eye
- 4 - Side board and rear tailgate locks
- 5 - Cylinder

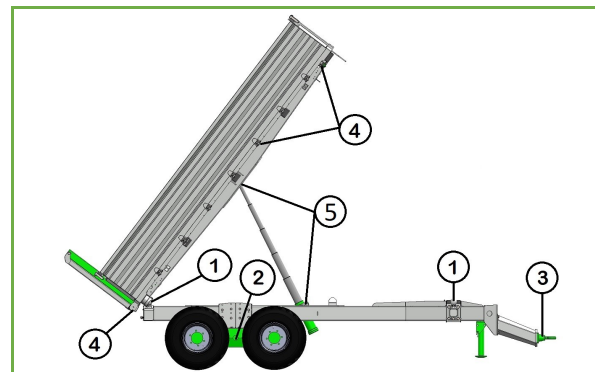

Figure 8-1: Lubrication points, general

8.3.2 Lubricants to be applied

Table 8-2: Lubrication schedule 1

No.	Lubrication point	Lubricant	Description	Lubrication frequency
1	Tipping pivot	Grease (EP2)	Lubricate ball with grease in tipped position	Every 8 hours of operation
2	Tandem assembly (2 x)	Grease (EP2)	Lubricate grease nipples on bushes underneath leaf springs	Every 8 hours of operation
3	Drawbar eye	Grease (EP2)	Lubricate grease nipple	Every 8 hours of operation
4	Board locks	Multispray (WD40)	Spray all pivoting points with multispray	Every 8 hours of operation
5	Cylinder	Grease (EP2)	Lubricate grease nipple	Every 8 hours of operation
-	Spindle-type parking jack	Grease (EP2)	Lubricate grease nipple	Every 20 operations or twice a year

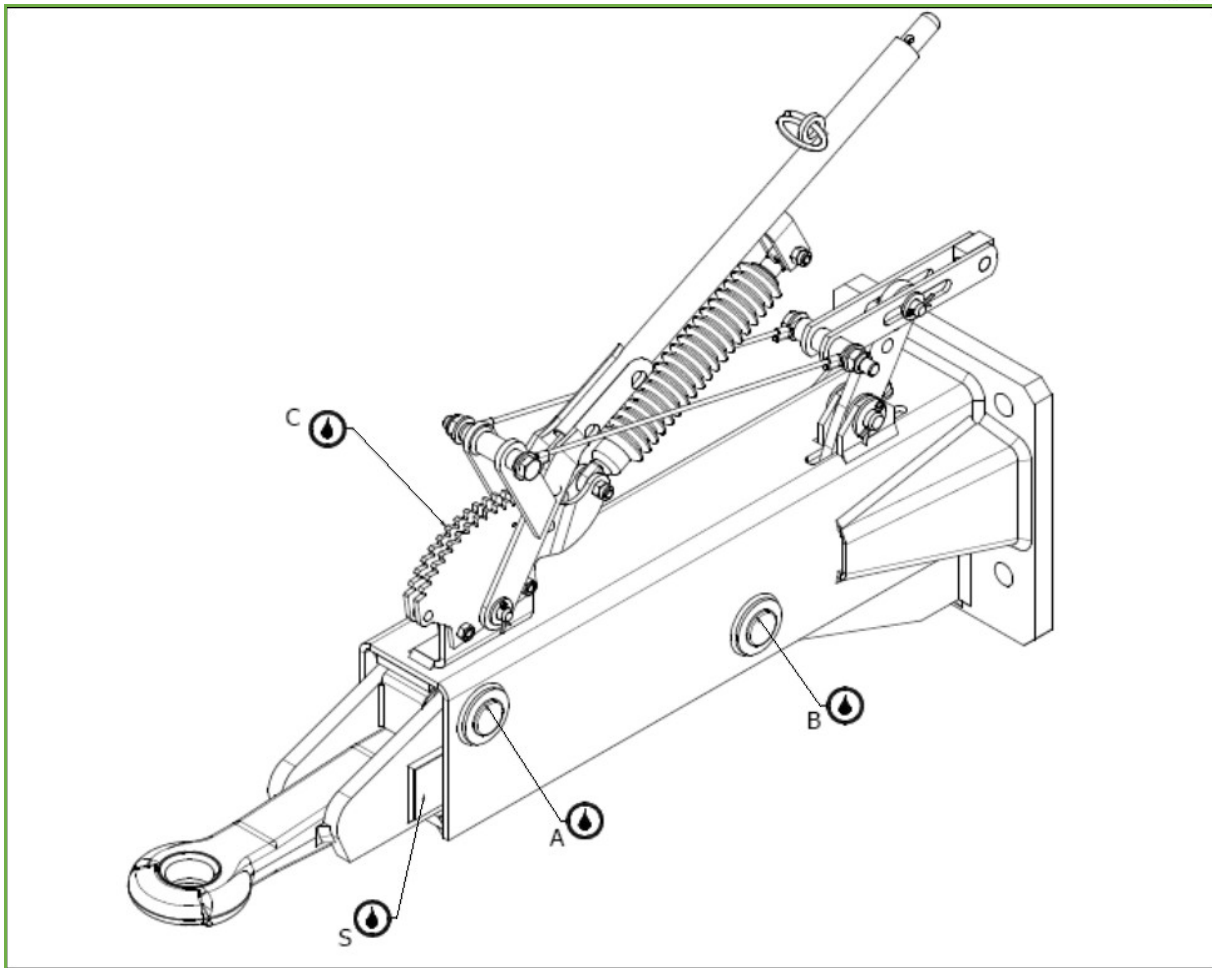

Figure 8-2: Drawbar and handbrake lubrication points

Table 8-3: Lubrication schedule 2

No.	Lubrication point	Lubricant	Description	Lubrication frequency
A+B	Overrun brake	Grease (EP2)	Lubricate grease nipples behind the little plastic covers	Every 20 operations or twice a year
C+S	Overrun brake	Copper grease	Lubricate friction surfaces slightly with copper grease	Every 20 operations, or twice a year

8.3.3 Daily maintenance

1. Check tyre pressures. Please refer to Table 8-1.
2. Check the lights and replace any faulty bulbs (faulty LED fittings to be replaced).
3. Check all nuts and bolts before every operation and re-tighten if necessary.
4. Check the hydraulic circuit for leakage before every operation.
5. Check the pneumatic circuit for leakage before every operation.
6. Drain moisture from the tipping trailer's air vessel.
7. Check the brakes and control instruments.
 - a. When coupling the tipping trailer's braking device to the tractor brake, check that the trailer's brakes have automatically set in the operative mode.
 - b. When disconnecting the tipping trailer from the tractor, check whether the trailer's braking device has operated automatically.

8.3.4 Annual maintenance

1. Replace hydraulic hoses every 6 years (or 6 years after the production date of the hose).
16. Replace pneumatic hoses every 6 years (or 6 years after the production date of the hose).
17. Check the depth of tyre treads and replace tyres if necessary.
18. Check tyres for any damage or dry rot and replace tyres if necessary.
19. Check the brakes and control instruments.
20. Block the wheels and check whether the handbrake can be operated by hand when the vehicle is uncoupled.
21. Check the functioning of the break-out braking device.
22. Check that the drain tap on the air vessel is functioning correctly.
23. Check the lights.
24. Clean the Wabco air filter (once every 2 years).

9. FAILURES

9.1 Break-out braking device

Statutorily-braked tipping trailers (with a total weight of more than 750 kg) must be equipped with a break-out braking device.

If the coupling between the tractor and the tipping trailer is unexpectedly broken, this device should automatically bring the tipping trailer to a standstill.

The most frequently occurring failures are:

- broken cables
- blocked overrun brakes

9.2 Lighting

If the lights are not working

1. A dirty contact may be the cause, so first clean both the trailer plug and the socket using contact spray. Please refer to paragraph 9.3.2.

If the lights still don't work

Check all bulbs for proper functioning:

1. If necessary, remove the cover plate from the rear light.
2. Loosen the four screws holding the glass cover.
3. Replace the defective bulb and check the other bulbs and contact points for corrosion.
4. Replace the glass cover and, if applicable, the cover plate.



Figure 9-1: Lights



OBSERVATION:

If an LED rear light is involved, the entire unit must be replaced
(Attention: L/H and R/H version)

If the lights still don't work?

There must be a failure in the wiring. This is often caused by the plug.

1. Check the plug for loose wires.
2. Check whether the connections in the plug correspond with the connection schedule. Please refer to paragraph 9.3.
3. Check the connections in the rear lighting units.

9.3 Electric plug connections

9.3.1 ABS plug for hydraulics

OBSERVATION:

The numbering is specified in the plug itself.



Figure 9-2: 7-pole ABS plug (hydraulics)

Overview of 7-pole socket		
Pin	Function	Colour
1	+12 V Permanent for control valves	Red
2	+12 V via contact slot for electronics	Black
3	Earth for electronics (pin 2)	Yellow
4	Earth for control valves (pin 1)	Brown
5	ABS failure indication (low if voltage < +5 V)	White
6	CAN-H for EBS / ABS	Green/white
7	CAN-L for EBS / ABS	Brown/white

Figure 9-3: 7-pole ABS plug connection (hydraulics)

9.3.2 Trailer plug for lighting

OBSERVATION: The numbering is specified in the plug itself.

Specific for 12 V 7-pole cable kit.



Figure 9-4: pole plug connection for lighting

Overview of 7-pole socket (ISO 1724*)		
Pin	Function	Colour
1 / L	Direction indicator, left	Yellow
2/ 54g	Fog light	Blue
3/ 31	Mass	White
4/ R	Direction indicator, right	Green
5/ 58R	Rear light, right	Brown
6/ 54	Brake lights	Red
7/ 58L	Rear light, left	Black

Figure 9-5: 7-pole socket connection for lighting

10. TAKING THE TIPPING TRAILER OUT OF OPERATION

10.1 Storage of the tipping trailer

Ensure that the storage facility to be used is dry and dust-free.

10.1.1 Preparatory work for short-term storage

Park the tipping trailer in a safe manner:

- Park the tipping trailer on a stable and level surface.
- Always apply the tipping trailer's handbrake when uncoupling the vehicle.
- If necessary, also block the wheels to prevent rolling.

10.1.2 Preparatory work for long-term storage

- Park the tipping trailer in a safe manner (as detailed above).
- Remove any caked dirt and clean the tipping trailer.
- Grease all lubrication points. Please refer to paragraph 8.3.1.
- If necessary, put the tipping trailer on blocks to relieve the load on the tyres.

11. DISASSEMBLY AND DISPOSAL

11.1 Disassembly

If the tipping trailer is disassembled, the prevailing local regulations for the disposal of waste at the time of the disassembly must be taken into account.

11.2 Disposal

The tipping trailer contains harmful substances, and it is illegal to release these into the environment. Make sure that the tipping trailer is disposed of such that it will be processed in a responsible manner, including the recycling of raw materials.

The tipping trailer may also be disposed of at a municipal waste recycling station or at a vehicle scrap yard.



ATTENTION:

It is the responsibility of the owner of the tipping trailer to dispose of the vehicle in a responsible manner.



OBSERVATION:

If the tipping trailer is fitted with a license plate, you should receive a vehicle waiver form upon the handing over of the trailer.

On the basis of this form, the tipping trailer can be de-registered with the local authority.

12. OVERVIEW OF FIGURES AND TABLES

12.1 Figures:

Figure 1-1: Model of serial plate	11
Figure 1-2: Various types of tipping trailer.....	12
Figure 2-1: Coupling of tipping trailer to tractor	13
Figure 2-2: Non-spring-loaded single-axle trailer (with hydraulic brakes).....	14
Figure 2-3: Fixed drawbar (pivotable drawbar eye).....	14
Figure 2-4: Drawbar with overrun brake (non-pivotable drawbar eye)	14
Figure 2-5: Spindle-type parking jack.....	15
Figure 2-6: Hydraulic parking jack.....	15
Figure 2-7: Sideways tipping.....	18
Figure 2-8: Shreds cover with open front wall and extension	19
Figure 2-9: Folding doors (with extension).....	20
Figure 2-10: Various couplings.....	21
Figure 2-11: Lighting and licence plate.....	22
Figure 2-12: Fixed drawbar (non-braked).....	23
Figure 2-13: overrun brake	23
Figure 2-14: Hydraulic brake connection (1-circuit)	24
Figure 2-15: Hydraulic braking system (single axle, non-spring-loaded)	25
Figure 2-16: Hydraulic braking system (spring-loaded tandem axle)	26
Figure 2-17: Hydraulic brake valve.....	27
Figure 2-18: 4-position handle (degree of loading).....	27
Figure 2-19: Connections of 2-circuit system.....	28
Figure 2-20: Automatic load-dependent braking power control (ALR; hydraulic).....	28
Figure 2-21: Pneumatic brake connections.....	29
Figure 2-22: Pneumatic hand-operated braking power control.....	30
Figure 2-23: Automatic load-dependent braking power control (ALR, pneumatic)	31
Figure 3-1: Location of stickers.....	33
Figure 3-2: Safety stickers.....	34
Figure 5-1: Rear tailgate locking hooks	36
Figure 5-2: Detail of rear tailgate locking hook.....	37
Figure 5-3: Hydraulic rear tailgate locking Figure 5-4: Locking hook system.....	38
Figure 5-5: Securing of the Z030/Z050 rear tailgate.....	39
Figure 5-6: Sideways tipping.....	39
Figure 5-7: Securing the side boards.....	40
Figure 5-8: Hydraulic side board locking.....	41
Figure 5-9: Hydraulic brake system (tandem axle).....	42
Figure 5-10: Overrun brake.....	43
Figure 5-11: Overrun braking system	44
Figure 5-12: Hydraulic lines of 1-circuit system.....	45
Figure 5-13: Braking system	45
Figure 5-14: Components of 2-circuit system.....	46
Figure 5-15: Hydraulic brake valve block (on drawbar).....	47
Figure 5-16: Hydraulic manifold valve block.....	48
Figure 5-17: Pneumatic braking system (manual).....	49
Figure 5-18: Pneumatic valve block with braking power control (manual).....	50

Figure 5-19: Pneumatic valve block with automatic braking power control	51
Figure 5-20: Locking of the tipping hinge.....	52
Figure 5-21: Hydraulic tilt ram	53
Figure 5-22: End stop valve	53
Figure 5-23: Mechanical safety bar	54
Figure 7-1: Adjustment of the drawbar.....	58
Figure 7-2: Coupling to tractor.....	58
Figure 7-3: Spindle-type parking jack.....	59
Figure 7-4: Hydraulic parking jack.....	60
Figure 7-5: Overrun brake	61
Figure 7-6: Hydraulic single circuit brake	62
Figure 7-7: Break-out safety feature with handbrake	63
Figure 7-8: Spindle-type handbrake.....	64
Figure 7-9: Double hydraulic brake coupling	65
Figure 7-10: ABS plug Figure 7-11: Double hydraulic connector.....	65
Figure 7-12: Rest position of hydraulic connector on manifold block.....	66
Figure 7-13: Positions of hydraulic brake valve with break-out device	66
Figure 7-14: Hydraulic 2-circuit brake.....	67
Figure 7-15: Pneumatic brake.....	68
Figure 7-16: Valves for tipping direction	70
Figure 7-17: Securing the rear tailgate locking hooks - models Z030 and Z050.....	71
Figure 7-18: Securing the rear tailgate locking hooks - Z045.....	72
Figure 7-19: Securing the side board.....	73
Figure 7-20: Position of hydraulic valves during tipping operations	74
Figure 7-21: Hoisting.....	76
Figure 8-1: Lubrication points, general	82
Figure 8-2: Drawbar and handbrake lubrication points.....	83
Figure 9-1: Lights.....	86
Figure 9-2: 7-pole ABS plug (hydraulics).....	87
Figure 9-3: 7-pole ABS plug connection (hydraulics).....	87
Figure 9-4: pole plug connection for lighting.....	88
Figure 9-5: 7-pole socket connection for lighting.....	88

12.2 Tables:

Table 2-1: Overview of models Z030, Z045 and Z050 with available options.....	16
Table 2-2: Overview of models Z080 – Z100 with available options	17
Table 8-1: Overview of tyres	81
Table 8-2: Lubrication schedule 1	82
Table 8-3: Lubrication schedule 2	83

13. APPENDIXES

- Hydraulic schedule (if applicable)
- Pneumatic schedule (if applicable)

Hydraulic brake schematic

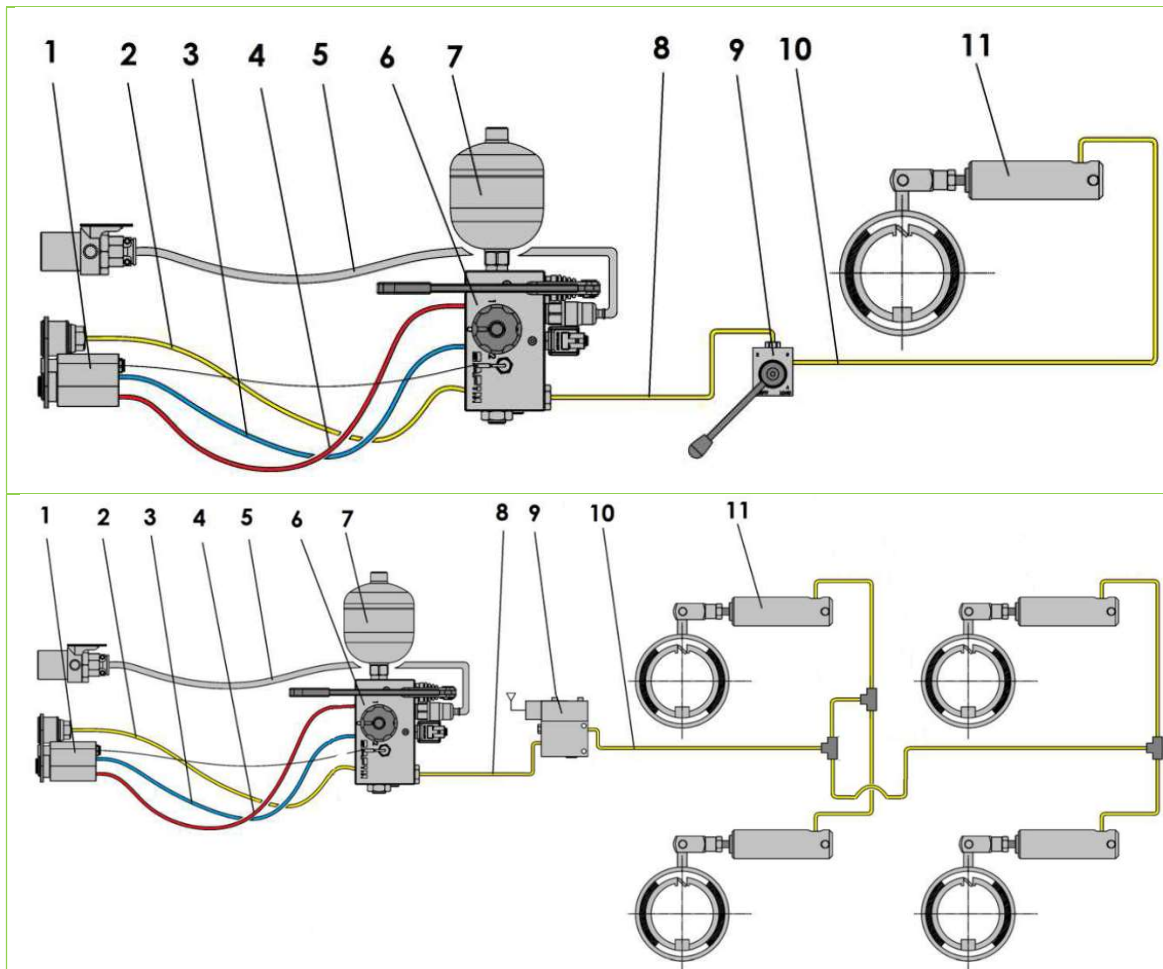

1	Double coupling with brake and control lines
2	Supply line
3	Return line
4	Main brake line
5	Electrical kit
6	Main brake valve
7	Accumulator
8	Brake line to loading degree valve
9	Single axle: Manual loading degree handle Tandem axle: ALR valve
10	Brake line to brake cylinder
11	Brake cylinder

Pneumatic brake schematic single axle

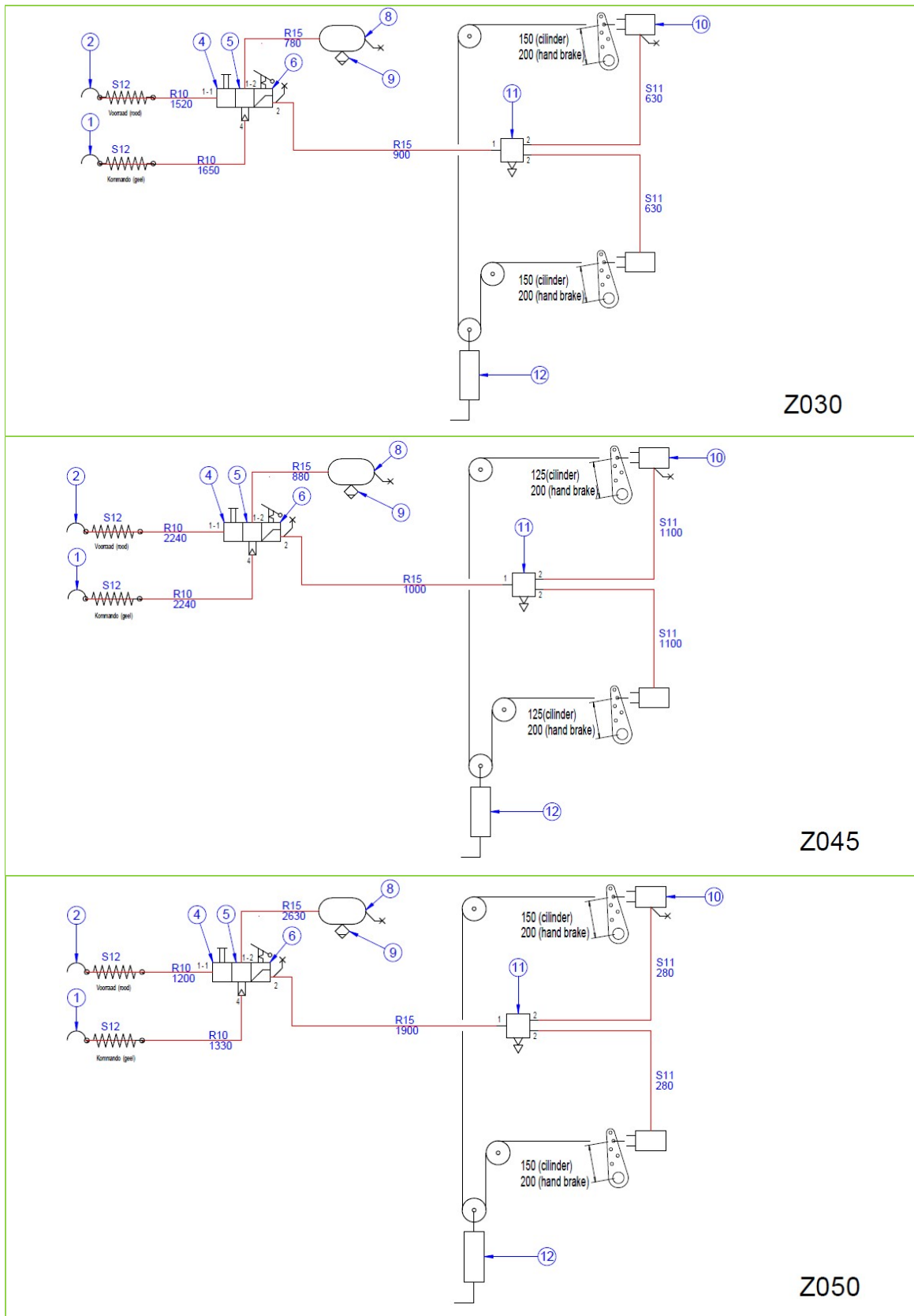

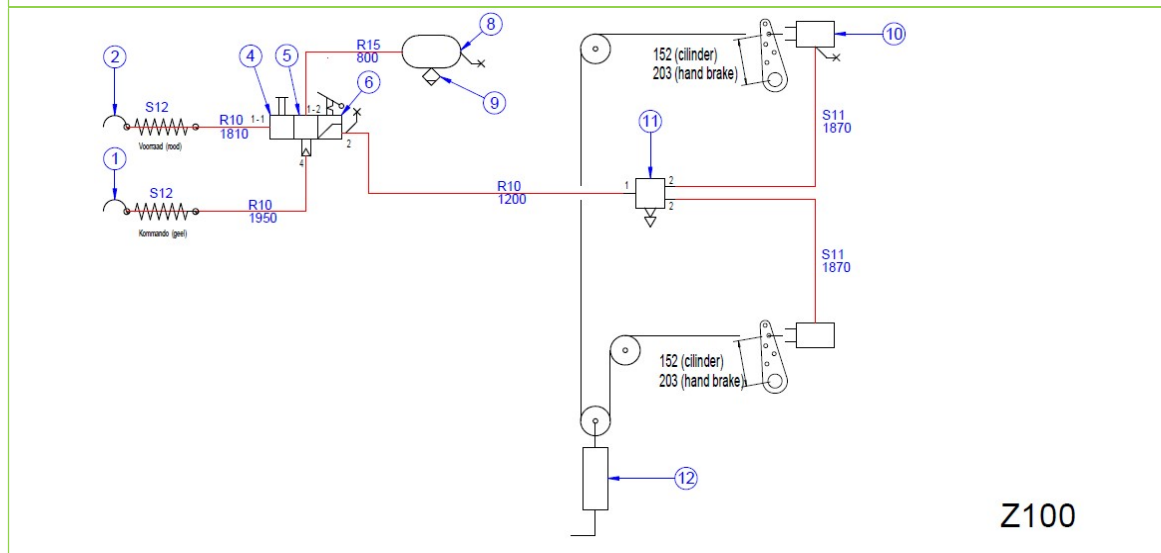
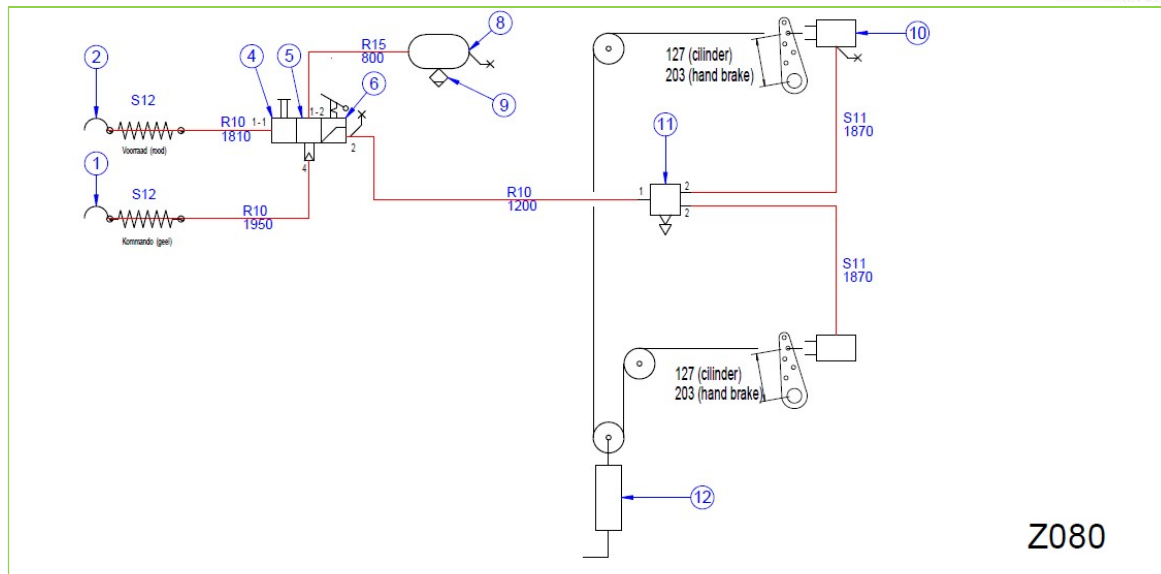

1	Coupling yellow
2	Coupling red
3	-
4	Release valve
5	Trailer brake valve
6	Manual valve degree of loading
7	-
8	Air vessel
9	Air release
10	Brake booster: 9" Z030; 16" Z045+Z050; 20" Z080+Z100
11	Quick release valve
12	Spindle handbrake

Pneumatic brake schedule tandem axle

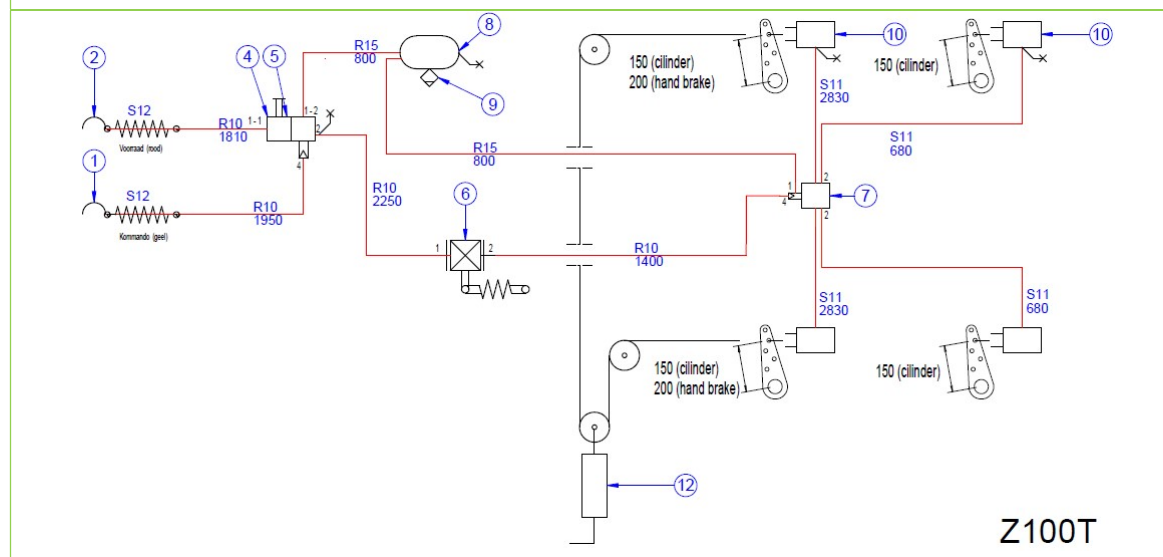
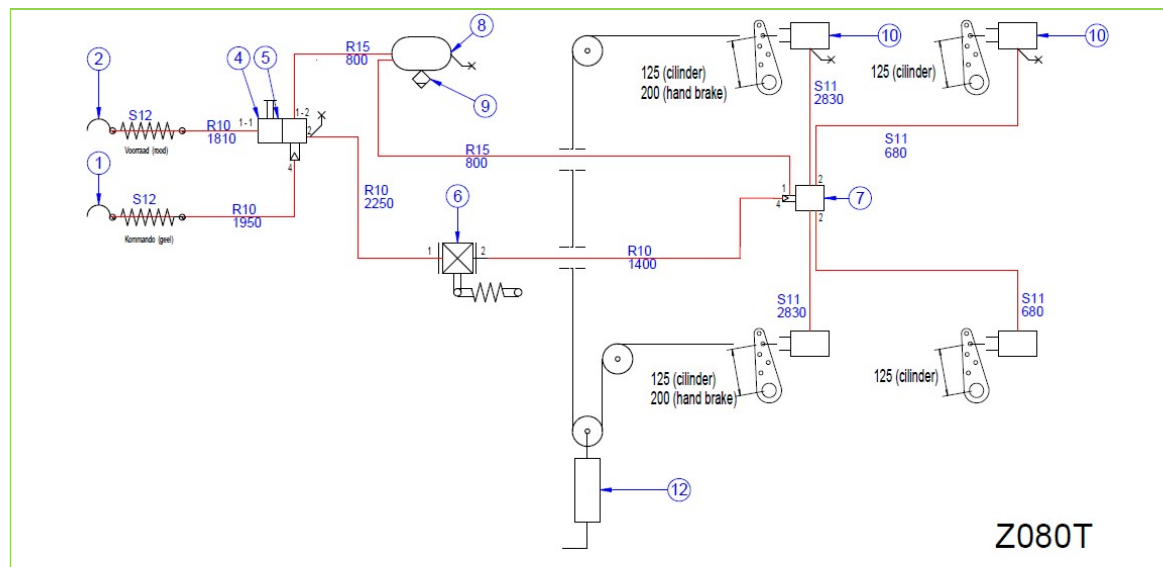

1	Coupling yellow
2	Coupling red
3	-
4	Release valve
5	Trailer brake valve
6	ALR valve
7	Relay valve
8	Air vessel
9	Air release
10	Brake booster: 16"
11	-
12	Spindle handbrake

